

Norwich Western Link

Transport Assessment

Appendix 9 – Traffic Flow Diagrams

Author: WSP UK Limited

Document Reference: 4.01.09

Version Number: 00

Date: March 2024

Contents

1	Traffic Flow Diagrams	3
---	-----------------------------	---

Figures

Figure 1-1	2029 Do Minimum AM Peak	4
Figure 1-2	2029 Do Minimum PM Peak	8
Figure 1-3	2029 Do Something AM Peak.....	12
Figure 1-4	2029 Do Something PM Peak.....	16
Figure 1-5	2029 Do Something + Mitigation AM Peak	20
Figure 1-6	2029 Do Something + Mitigation PM Peak	24
Figure 1-7	2039 Do Minimum AM Peak	28
Figure 1-8	2039 Do Minimum PM Peak	32
Figure 1-9	2039 Do Something AM Peak.....	36
Figure 1-10	2039 Do Something PM Peak.....	40
Figure 1-11	2039 Do Something + Mitigation AM Peak	44
Figure 1-12	2039 Do Something + Mitigation PM Peak	48

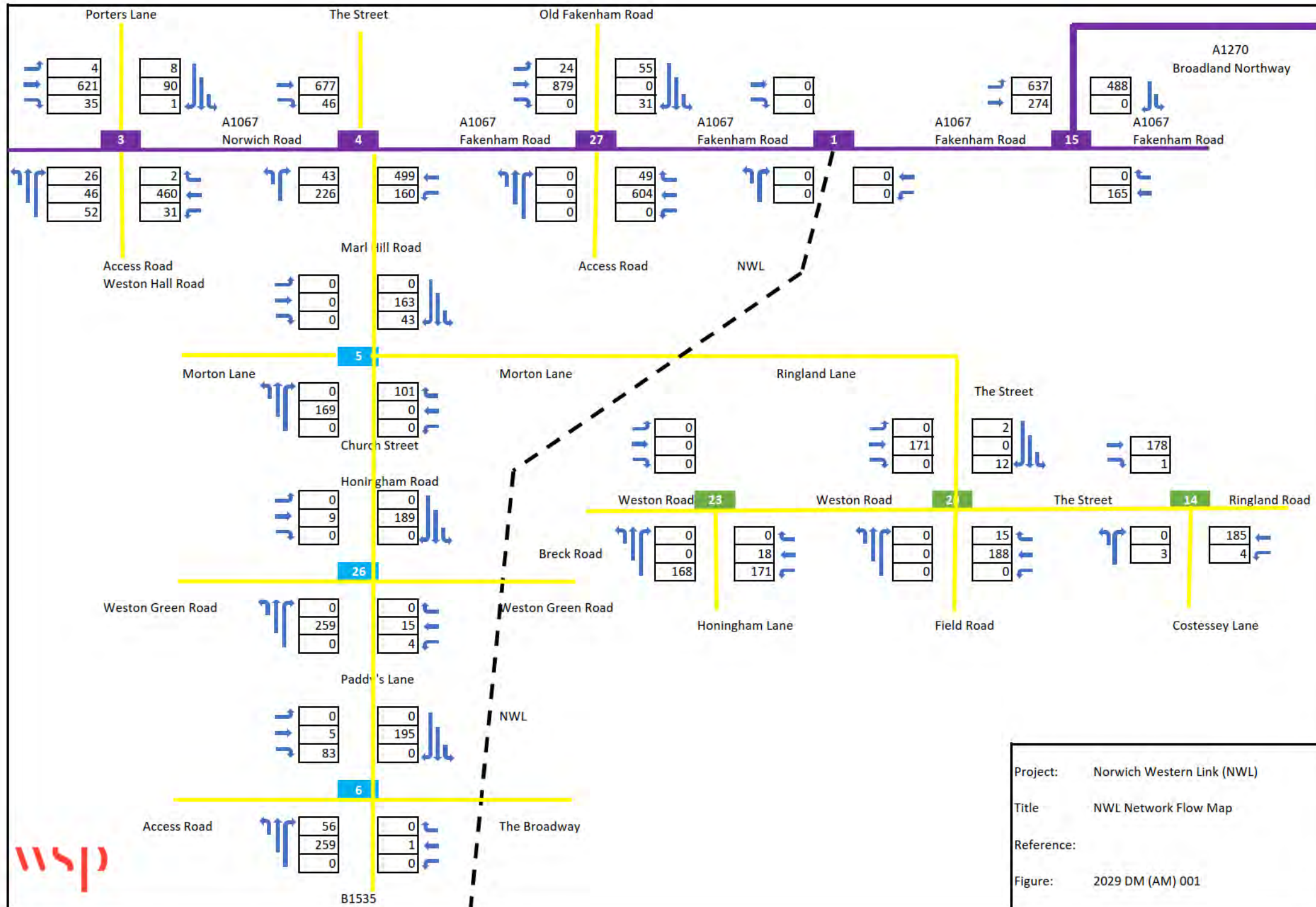


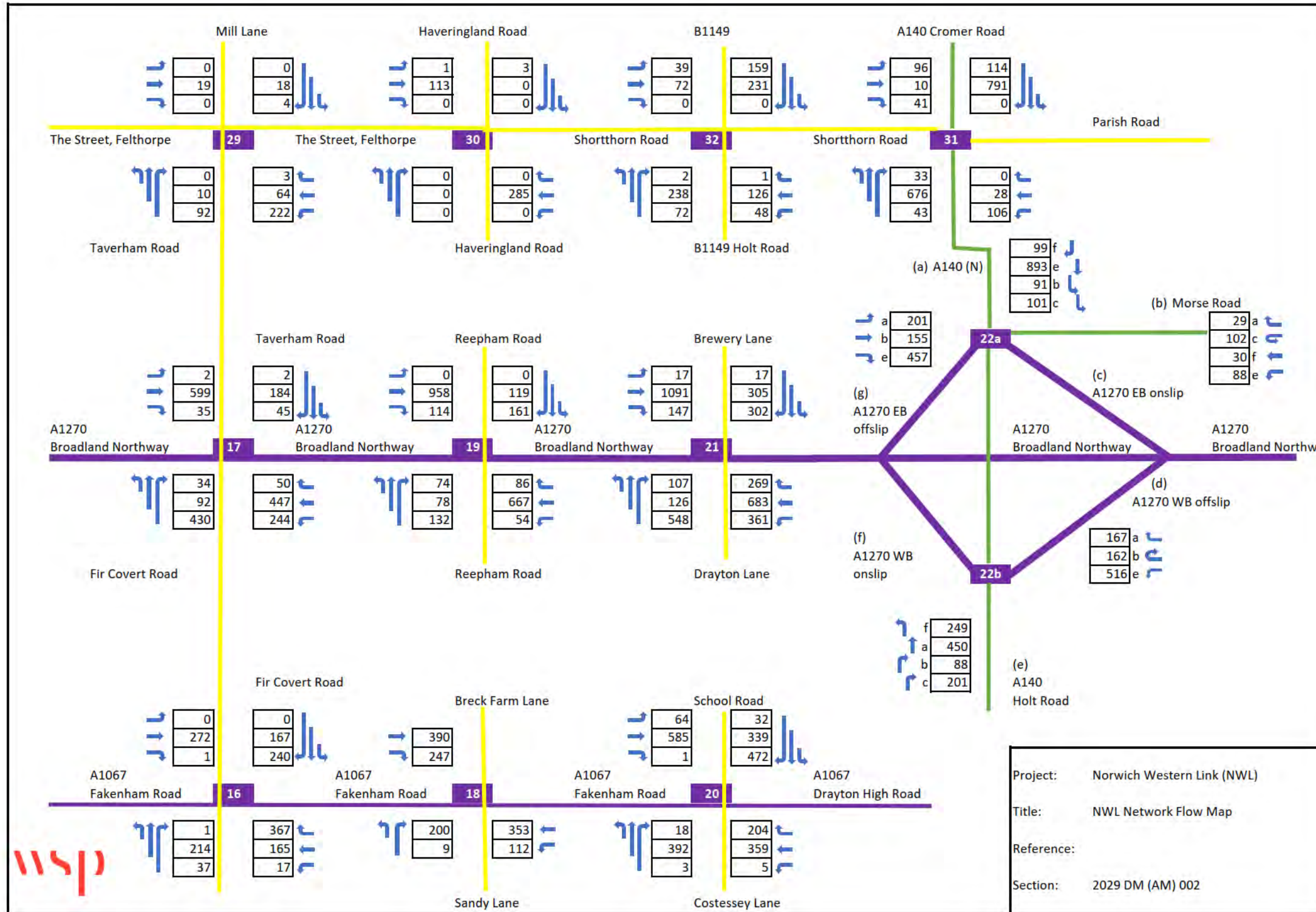
1 Traffic Flow Diagrams

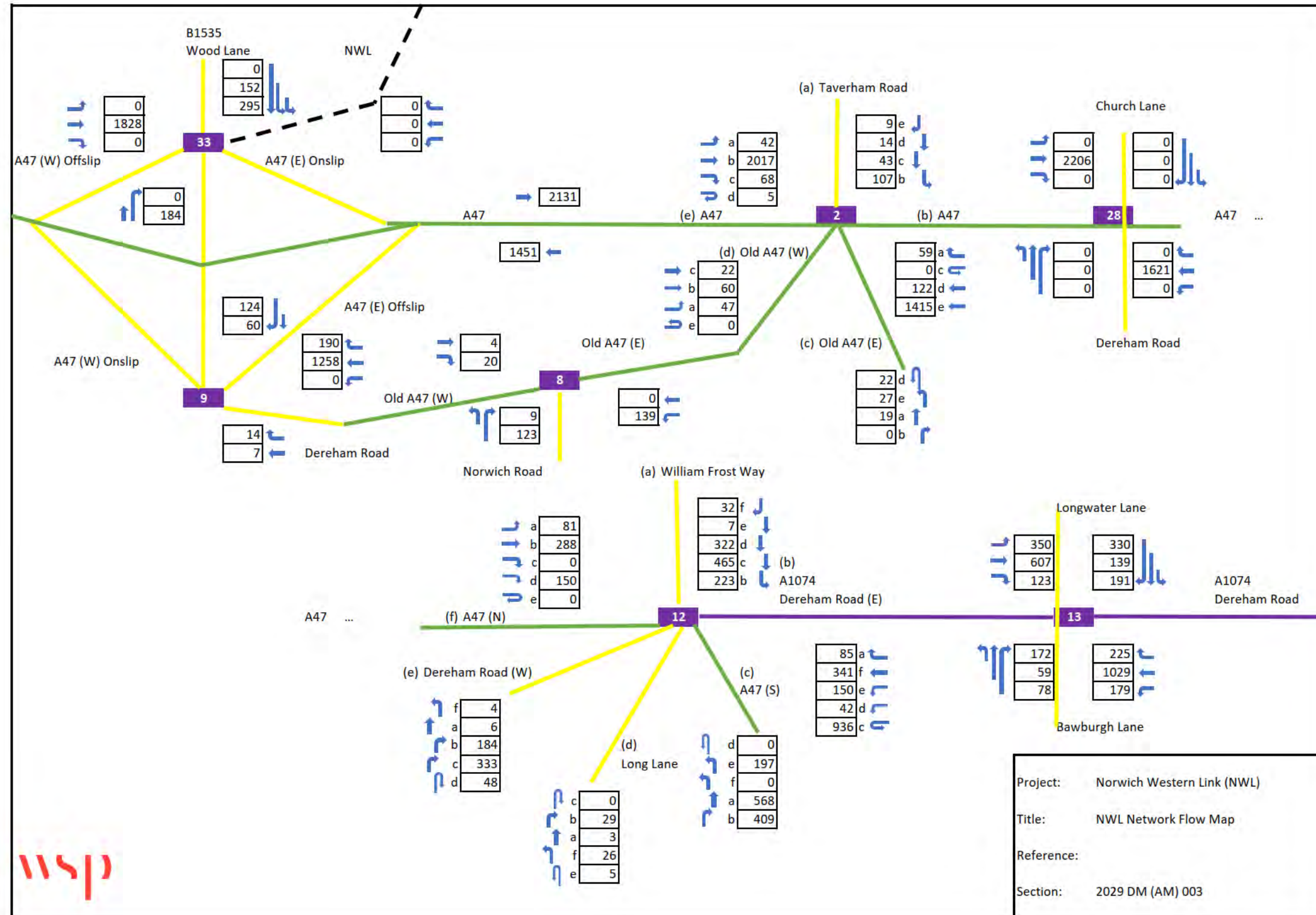
1.1.1 A series of junction flow diagrams showing AM and PM peak hour traffic flow diagrams for 2029 and 2039 future assessment years. The AM peak hour is considered to be 7.30am-8.30am and the PM peak hour assessed is 5-6pm on a typical weekday. The following scenarios are presented in the figures below:

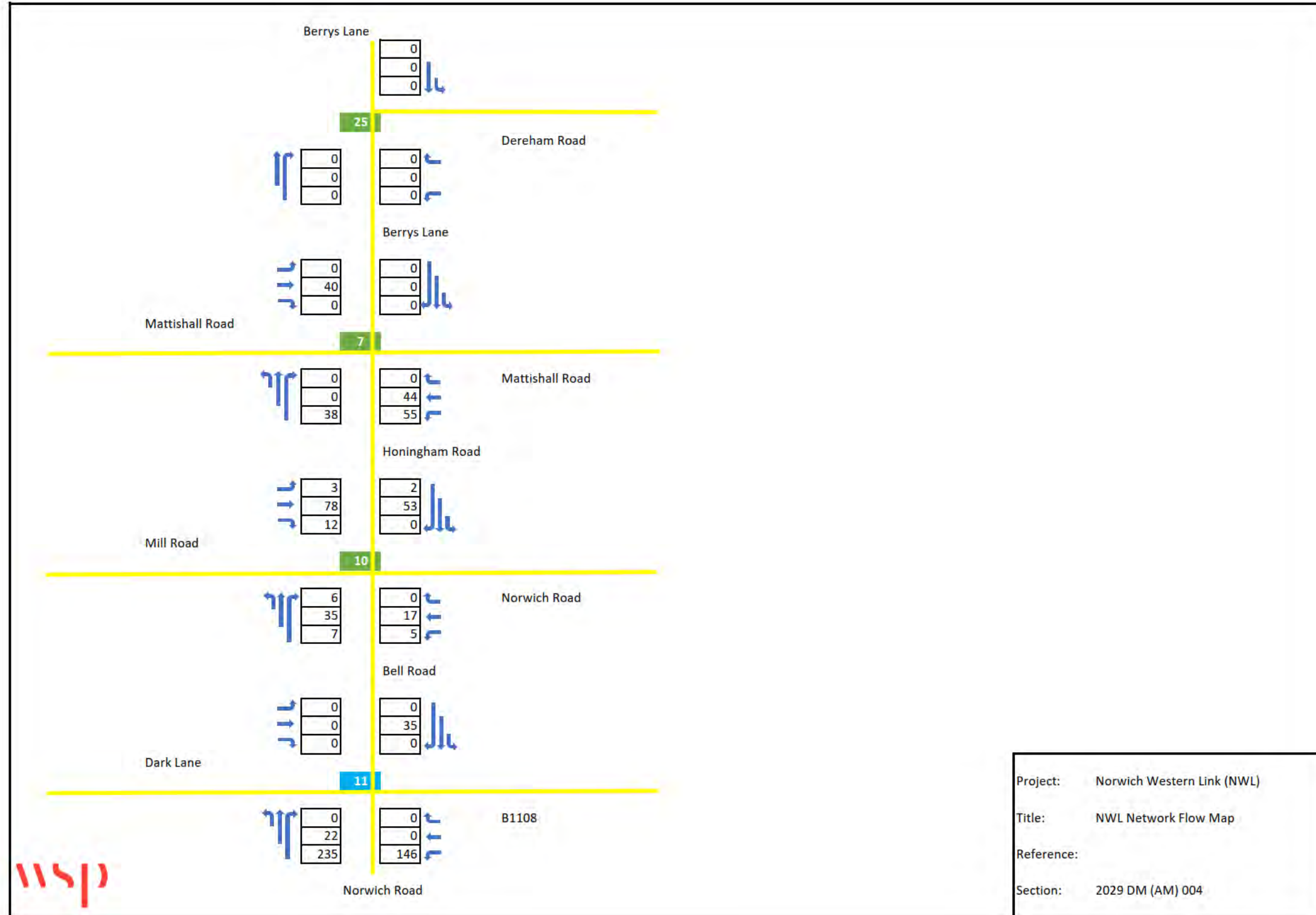
- Do Minimum – the future baseline without the Proposed Scheme. This includes committed developments and highways improvements.
- Do Something – the future situation with the Proposed Scheme added.
- Do Something + Mitigation - the future situation with the Proposed Scheme added with an additional package of traffic interventions in the wider network north of A1067 and south of A47.

Figure 1-1 2029 Do Minimum AM Peak





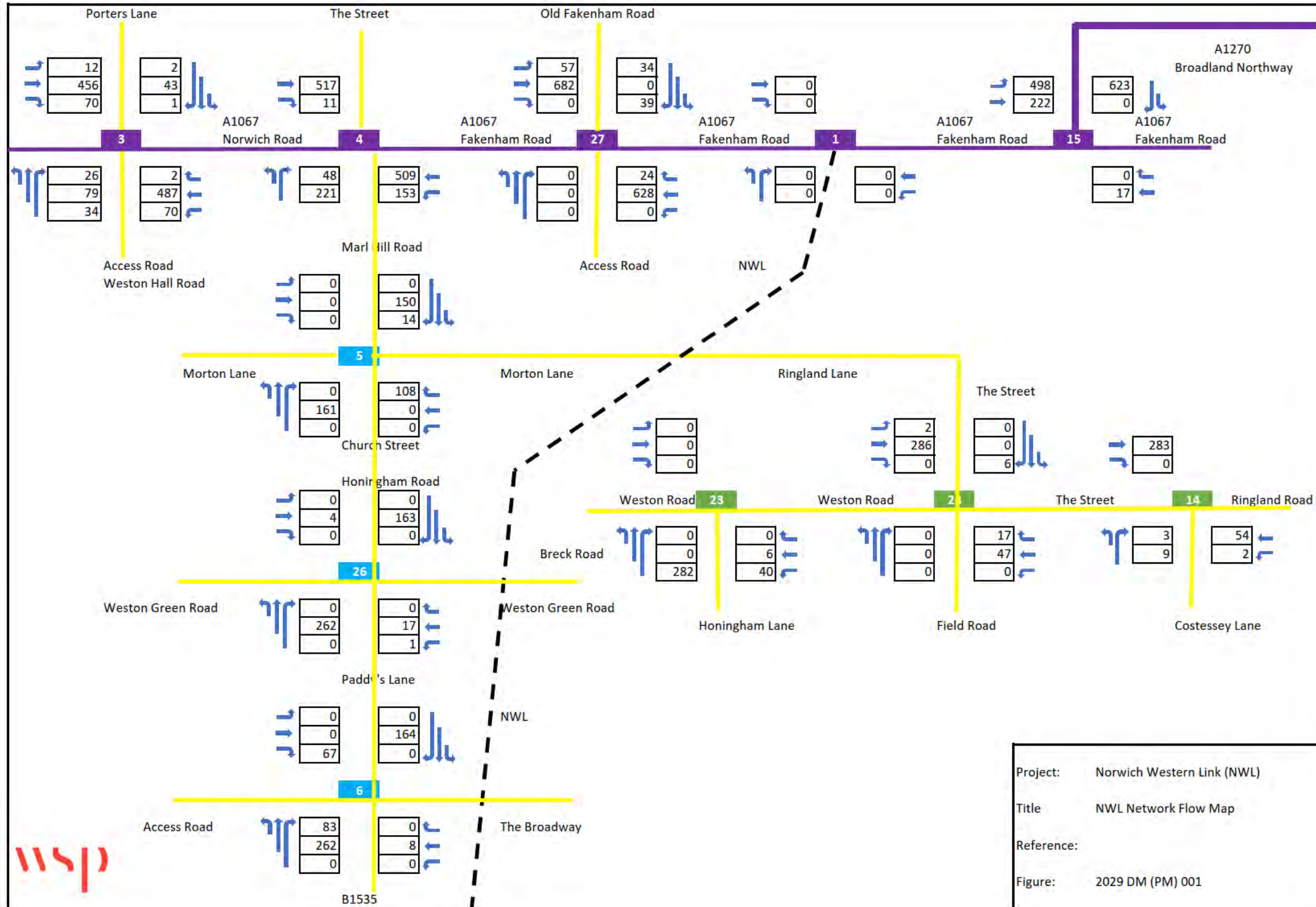


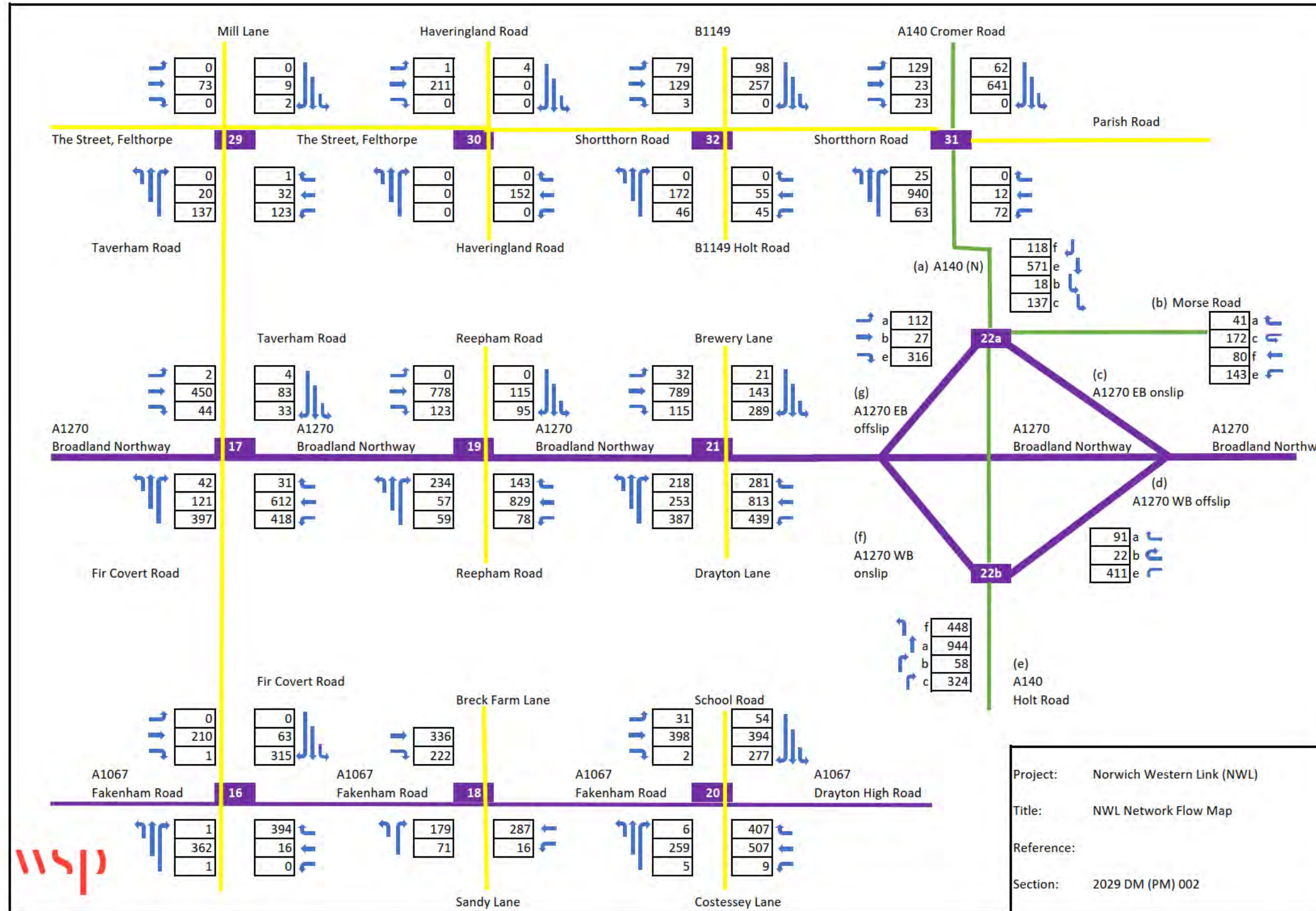


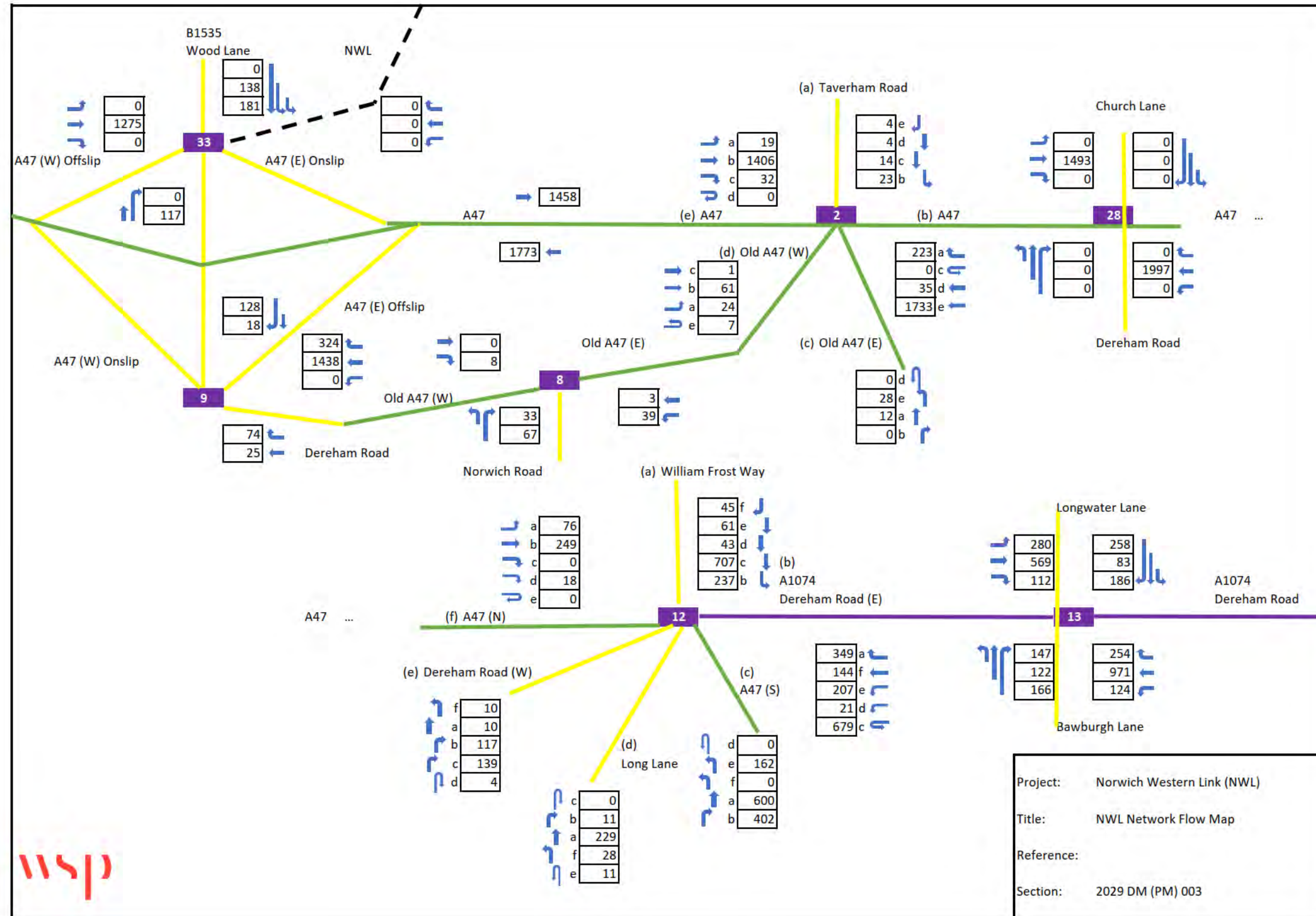
Project: Norwich Western Link (NWL)
 Title: NWL Network Flow Map
 Reference:
 Section: 2029 DM (AM) 004



Figure 1-2 2029 Do Minimum PM Peak







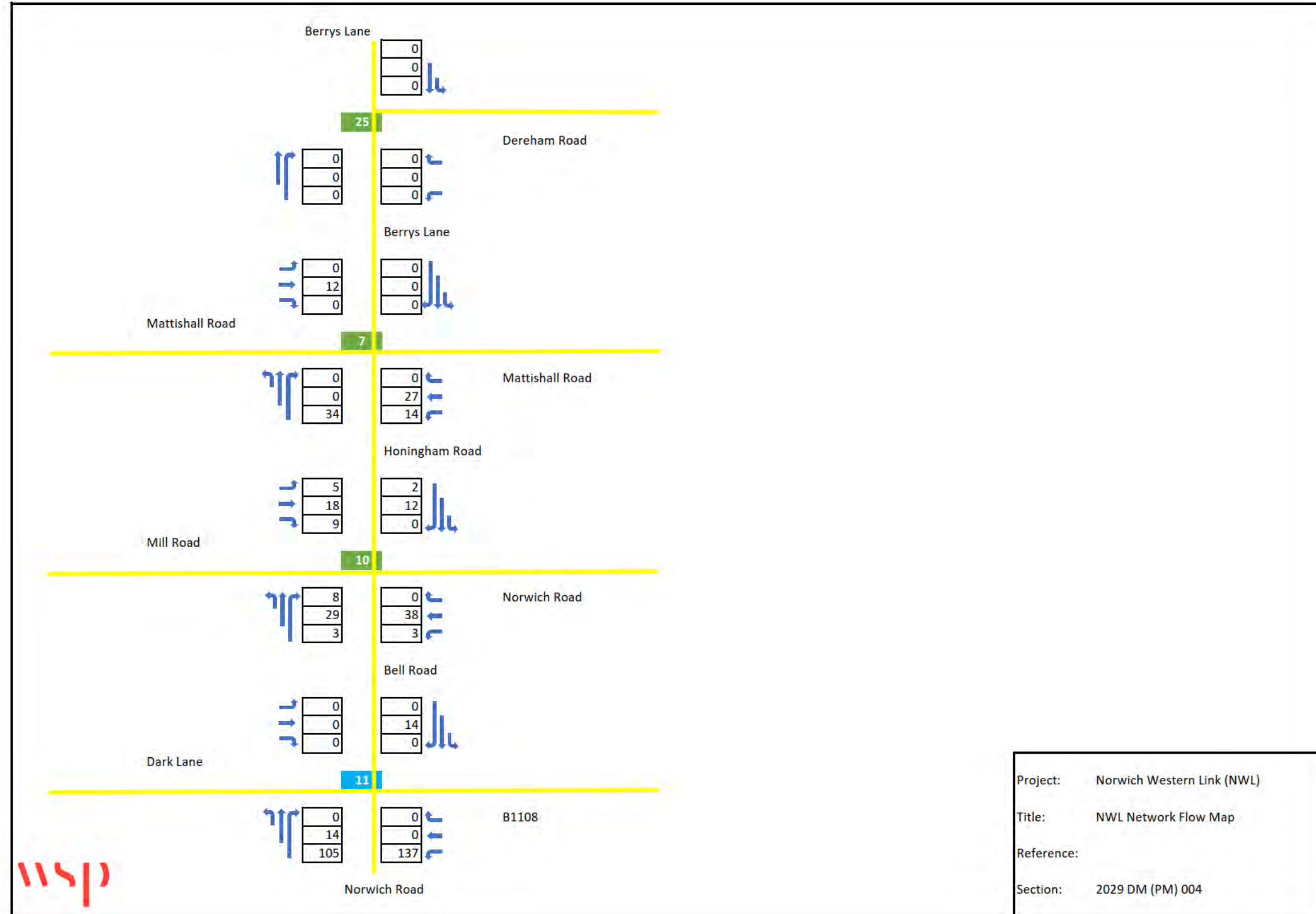
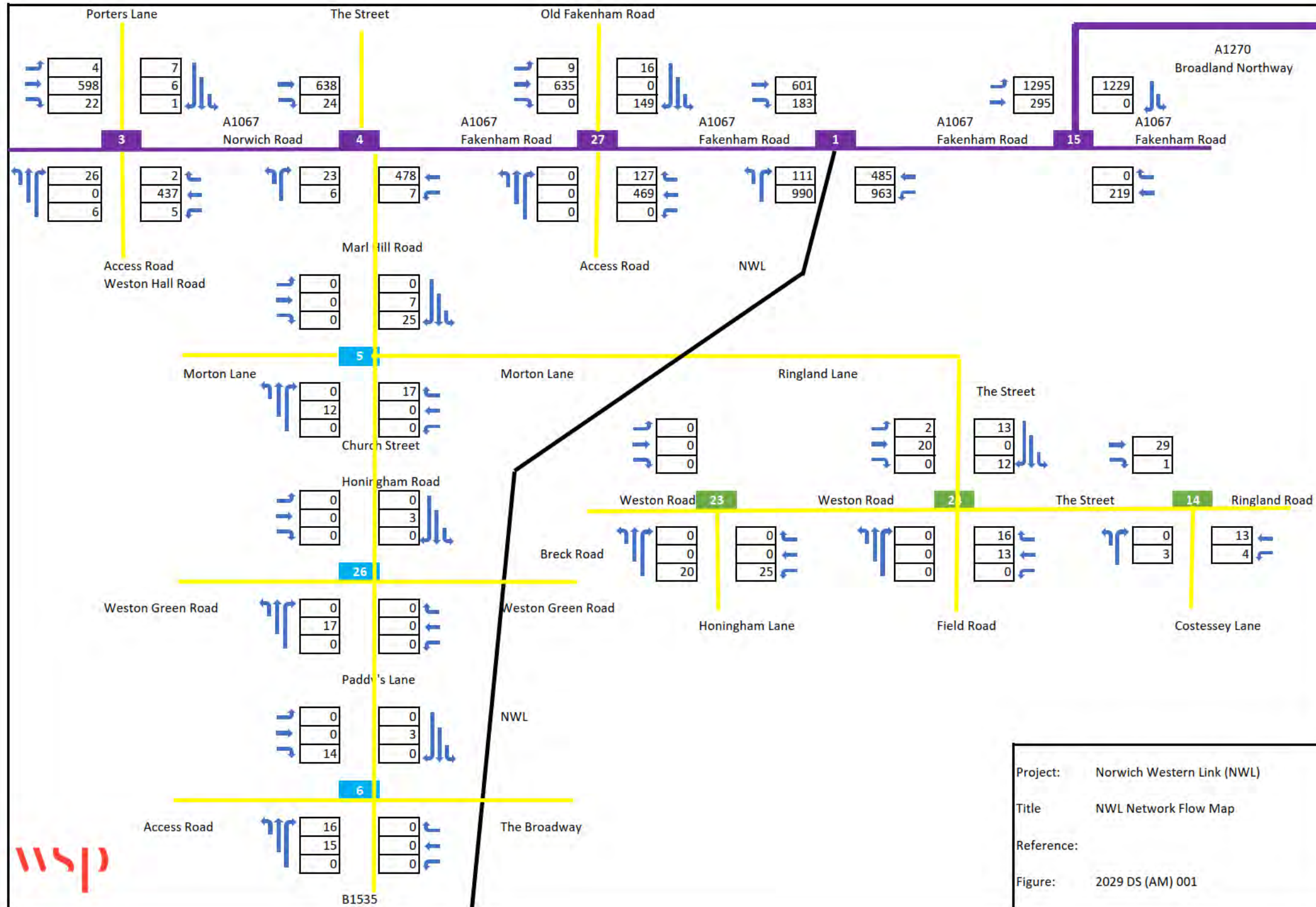
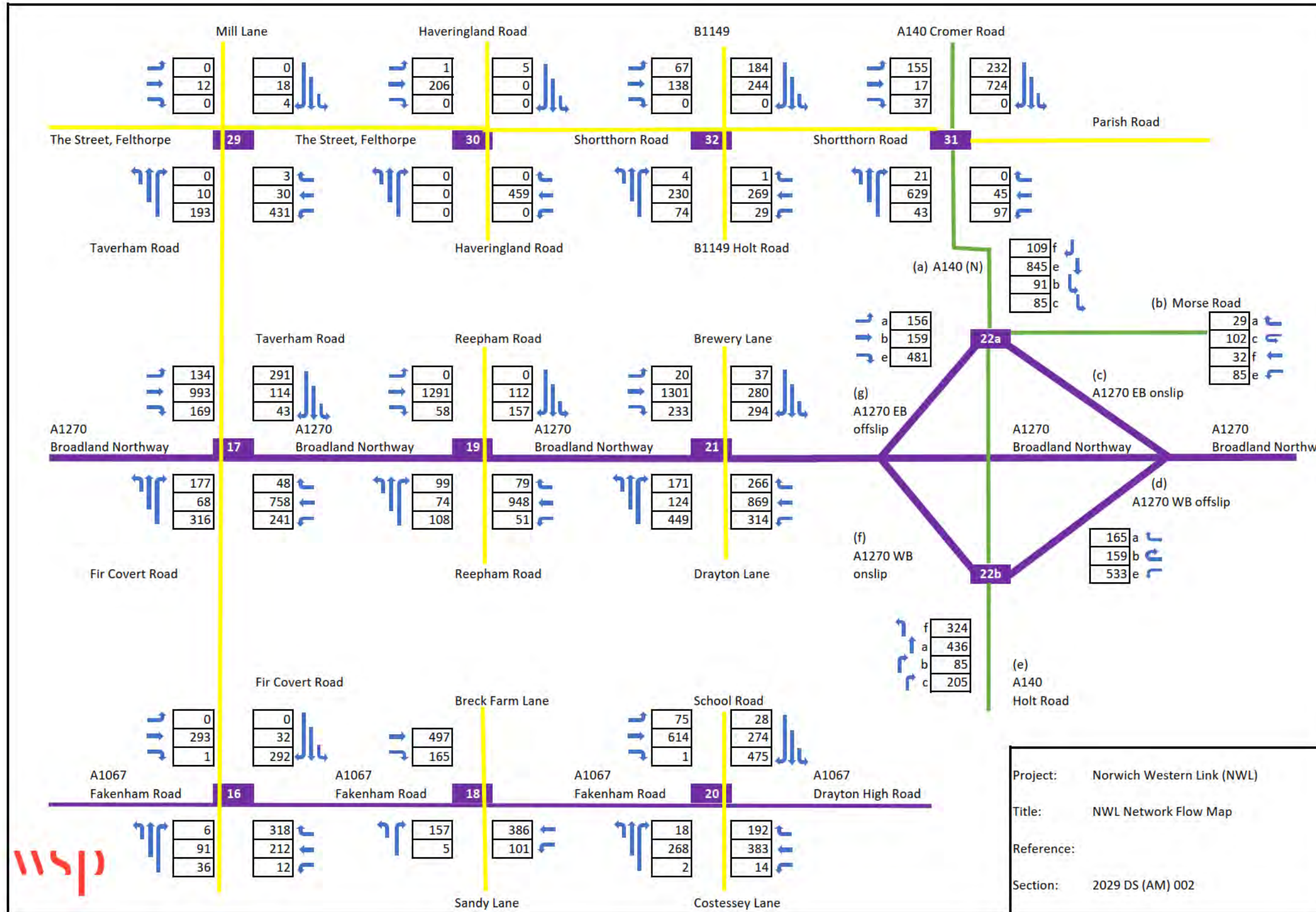
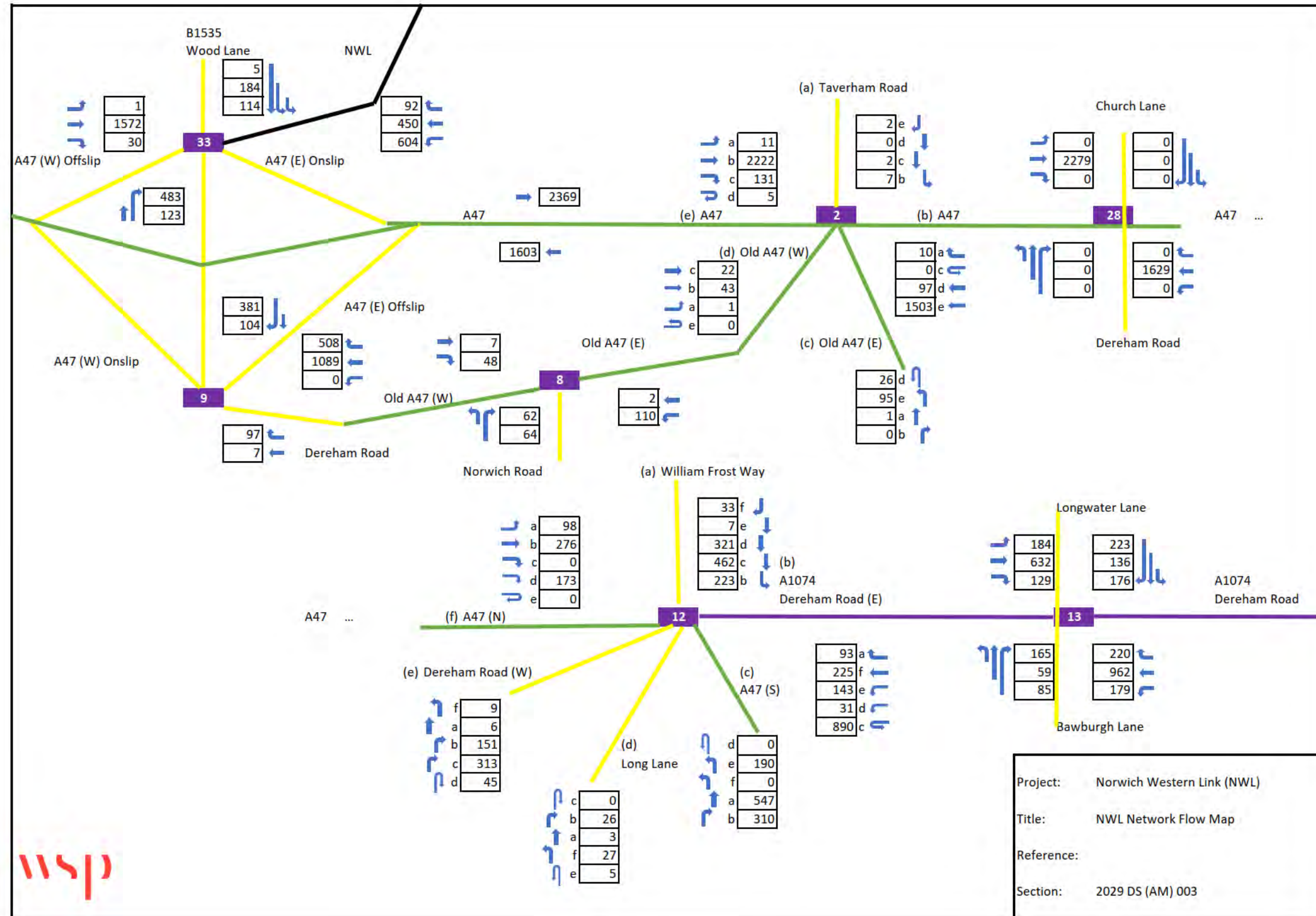
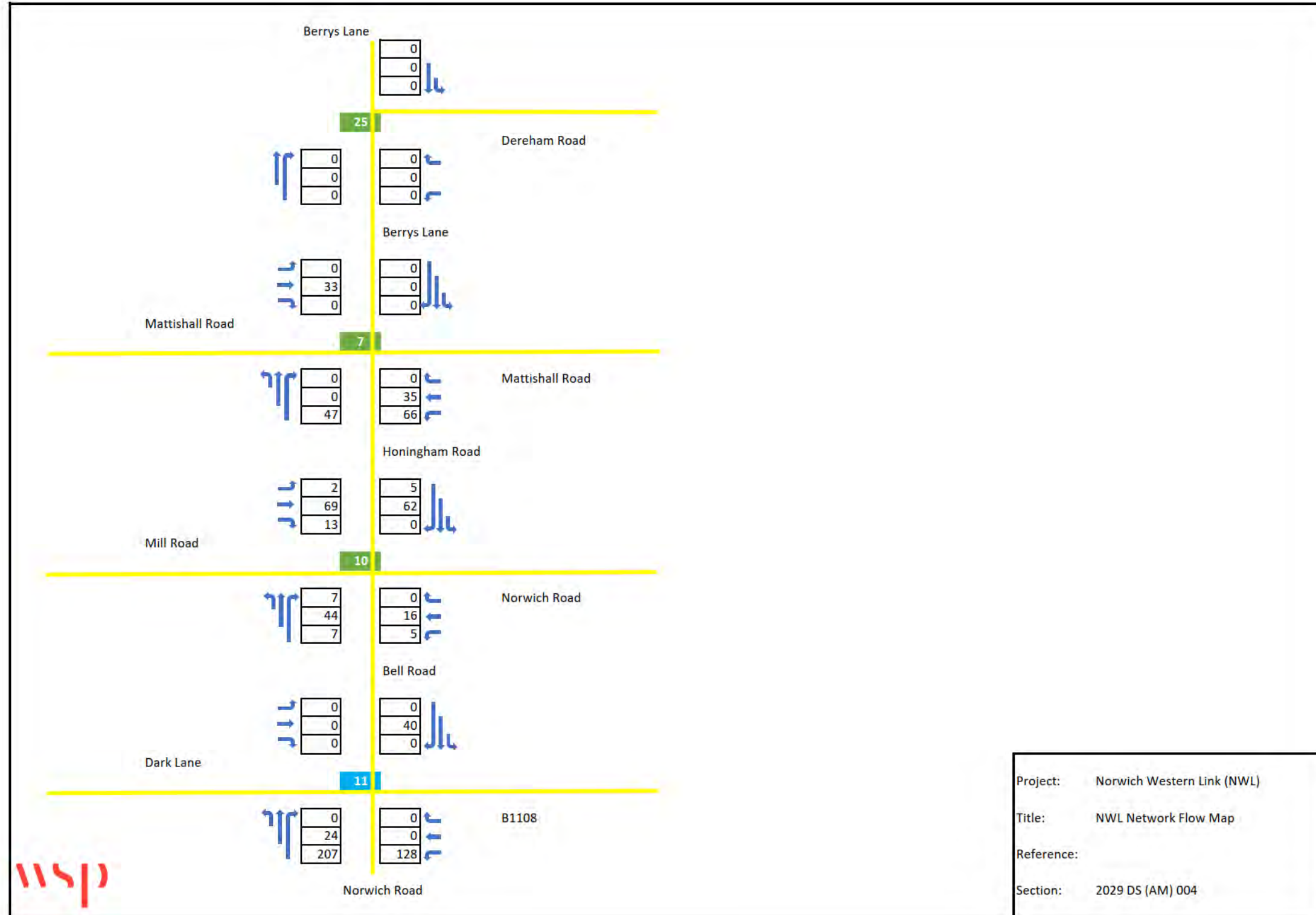


Figure 1-3 2029 Do Something AM Peak





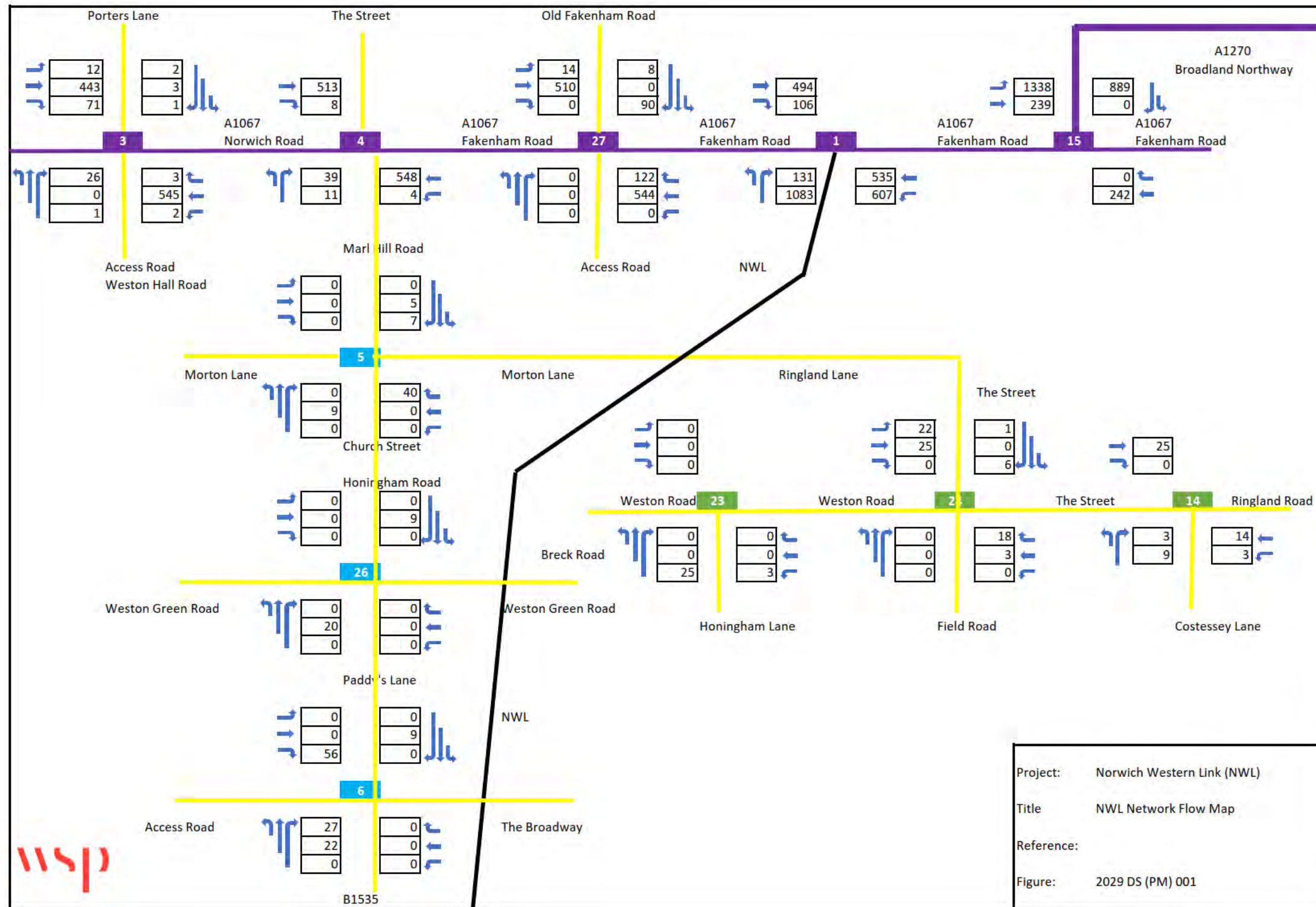


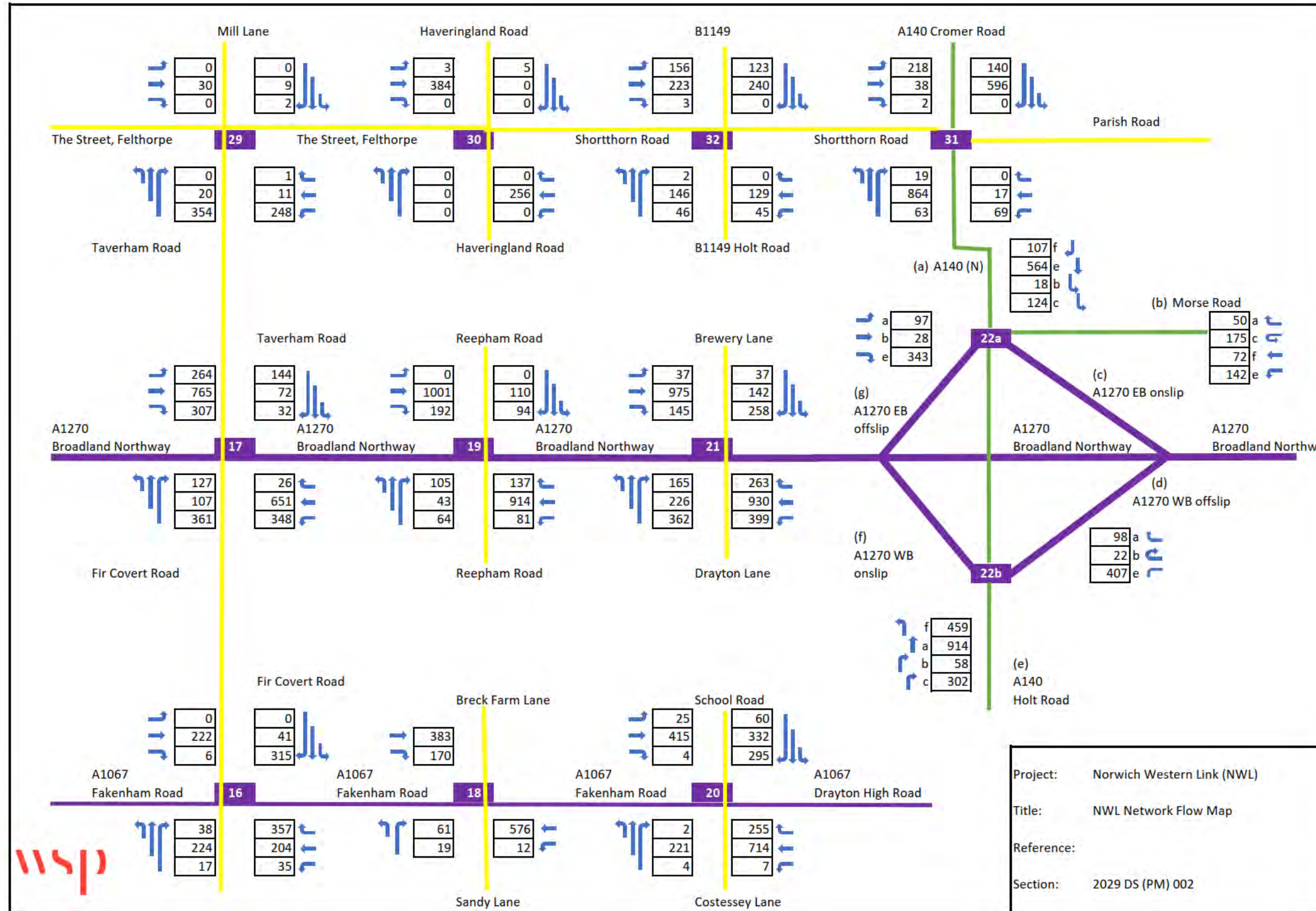


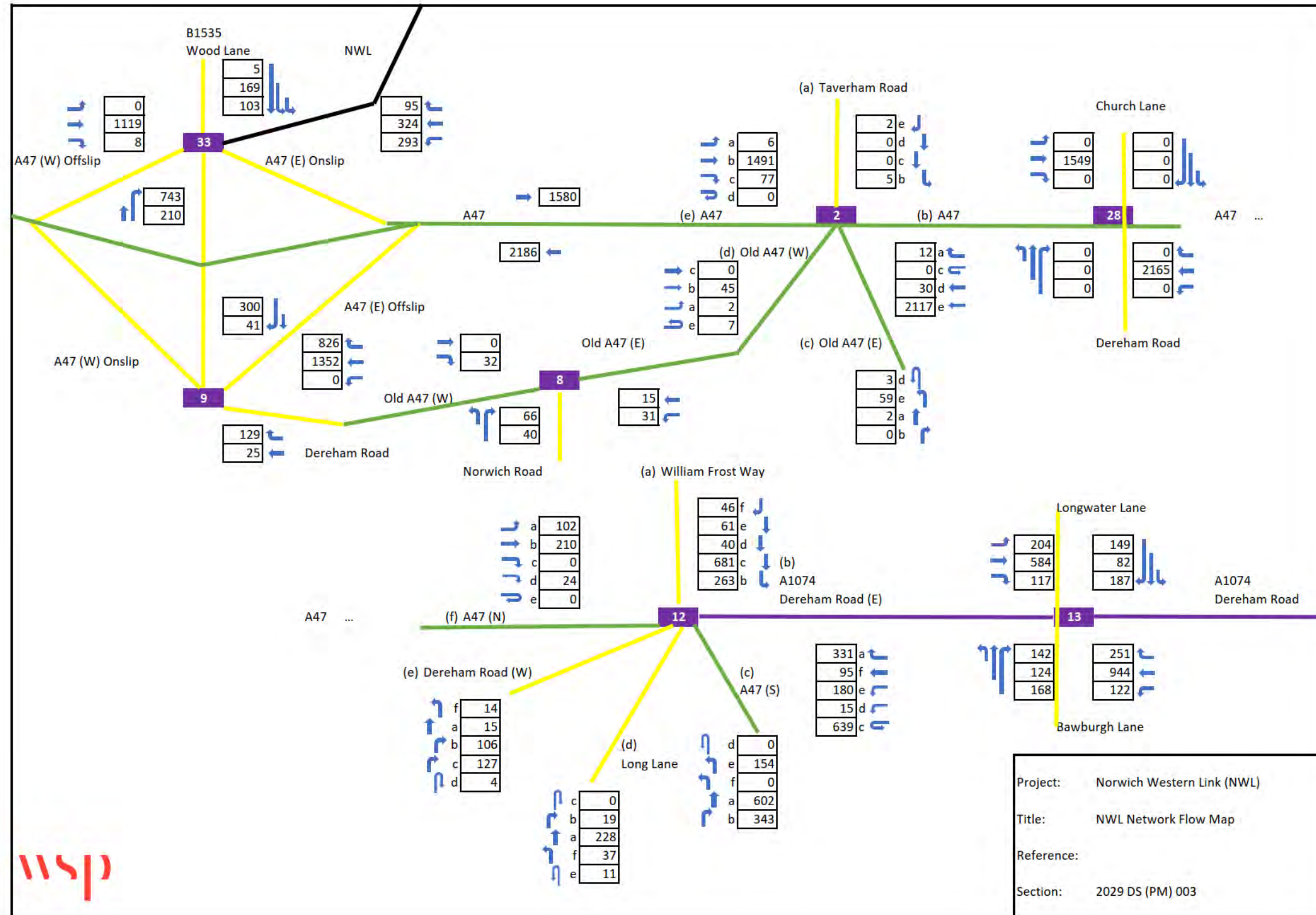
Project: Norwich Western Link (NWL)
 Title: NWL Network Flow Map
 Reference:
 Section: 2029 DS (AM) 004

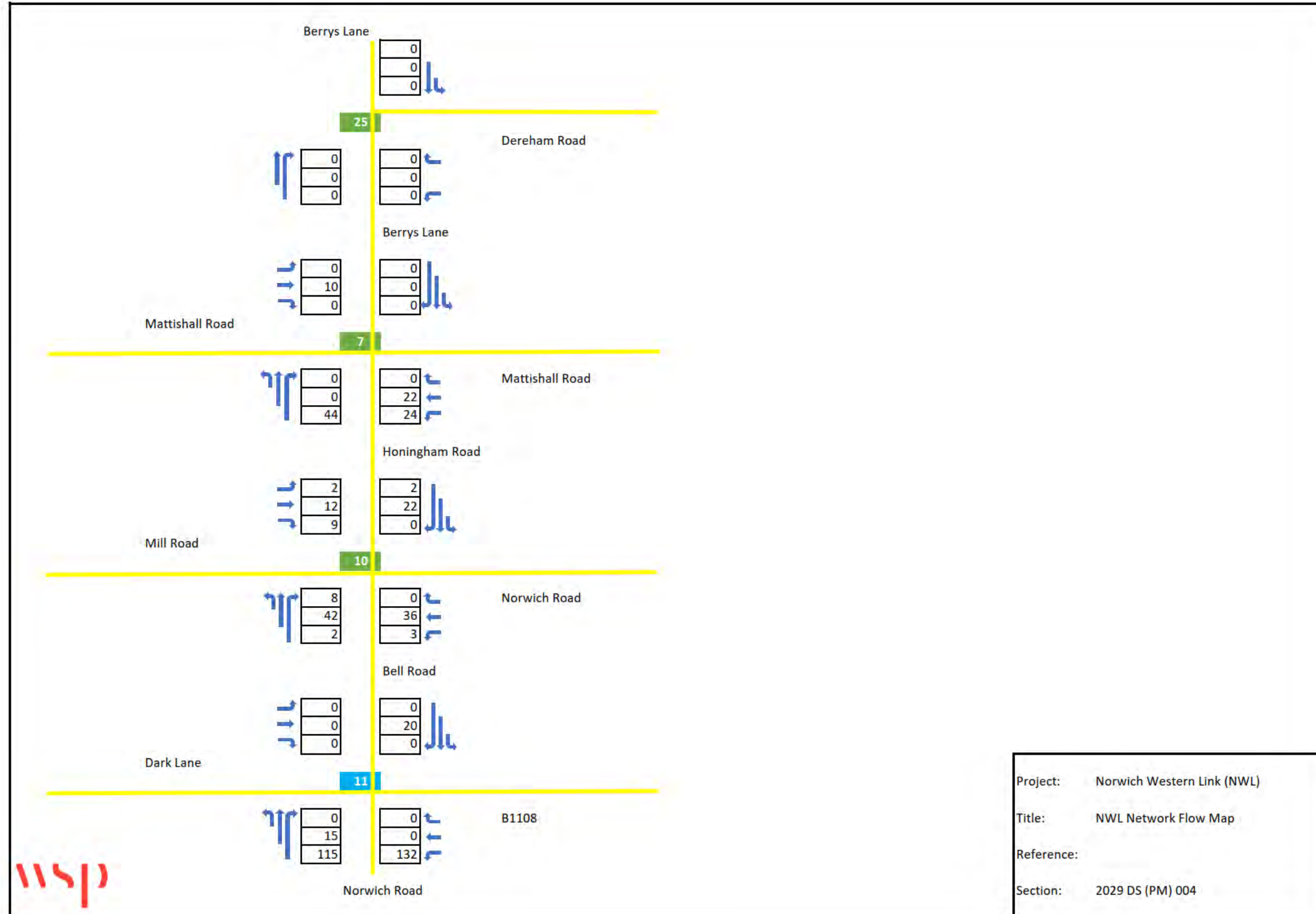


Figure 1-4 2029 Do Something PM Peak



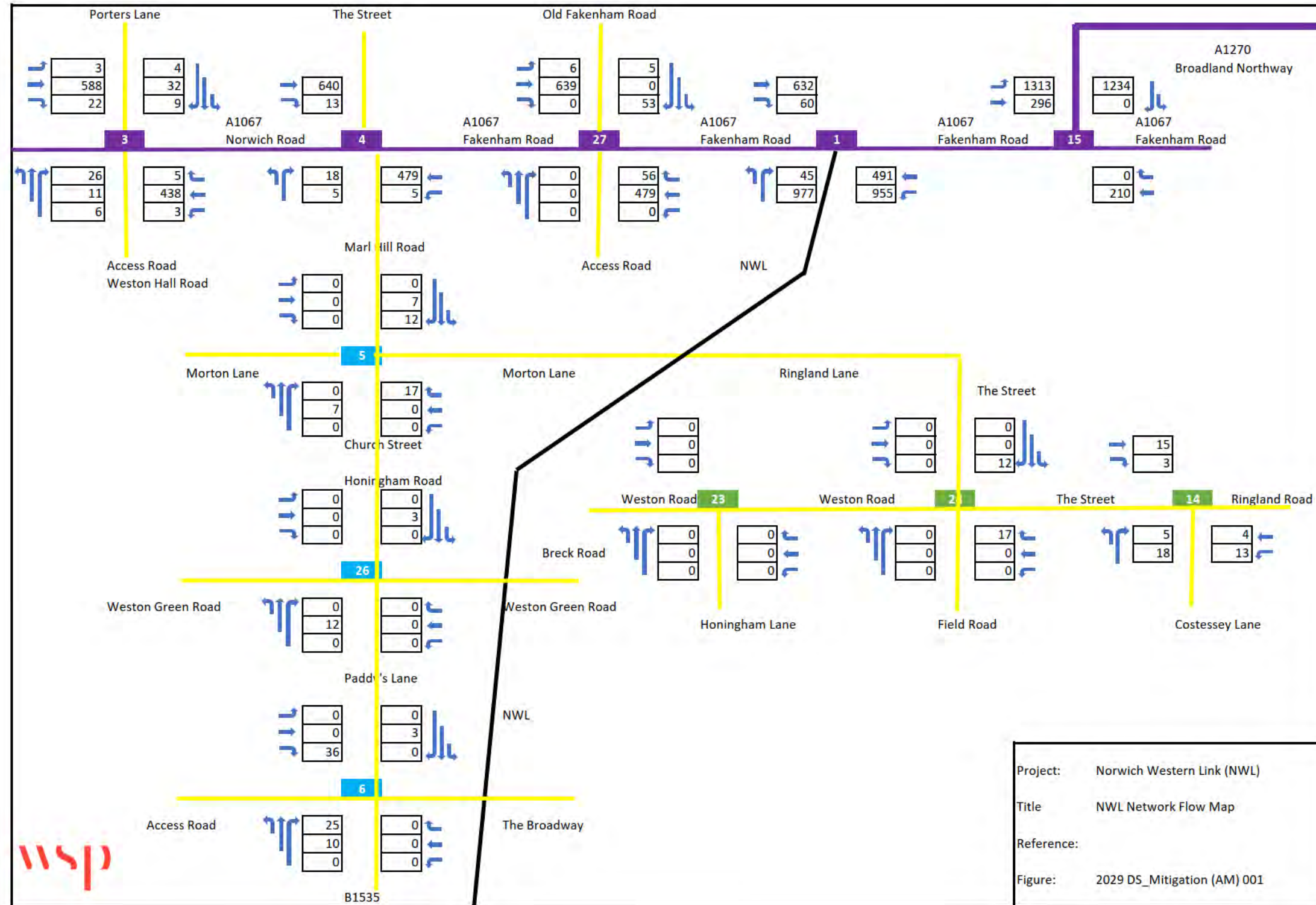


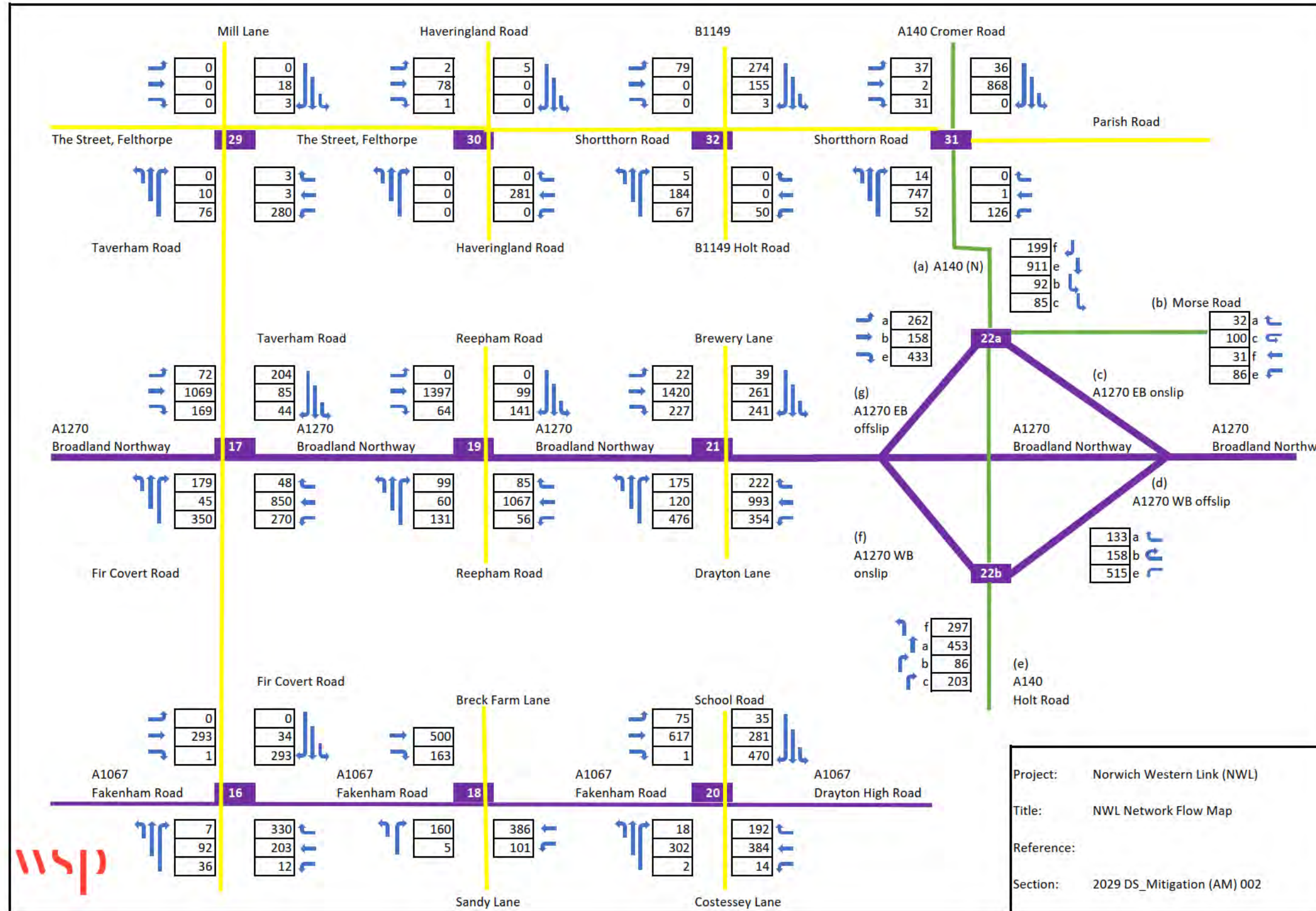


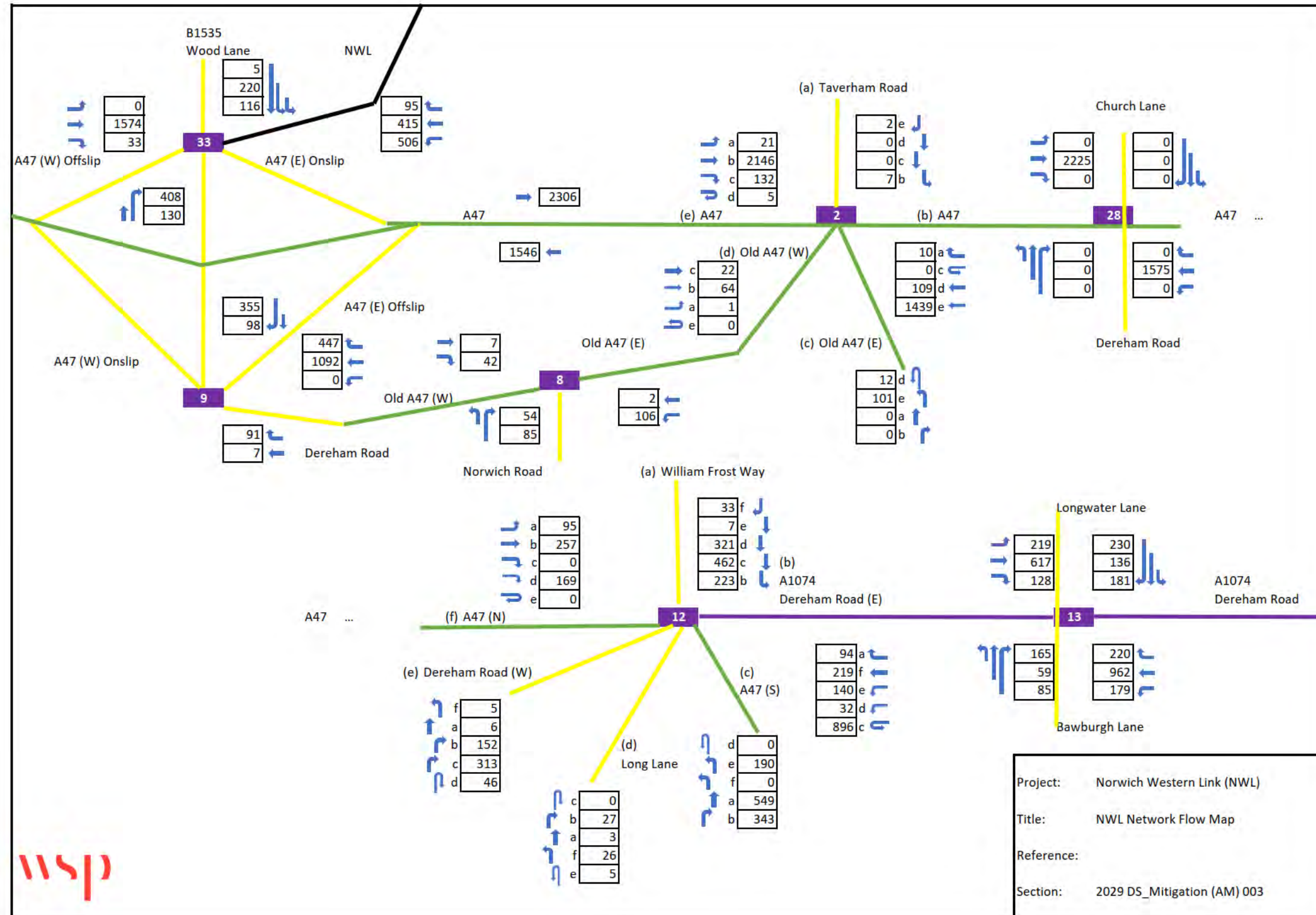


Project: Norwich Western Link (NWL)
 Title: NWL Network Flow Map
 Reference:
 Section: 2029 DS (PM) 004

Figure 1-5 2029 Do Something + Mitigation AM Peak

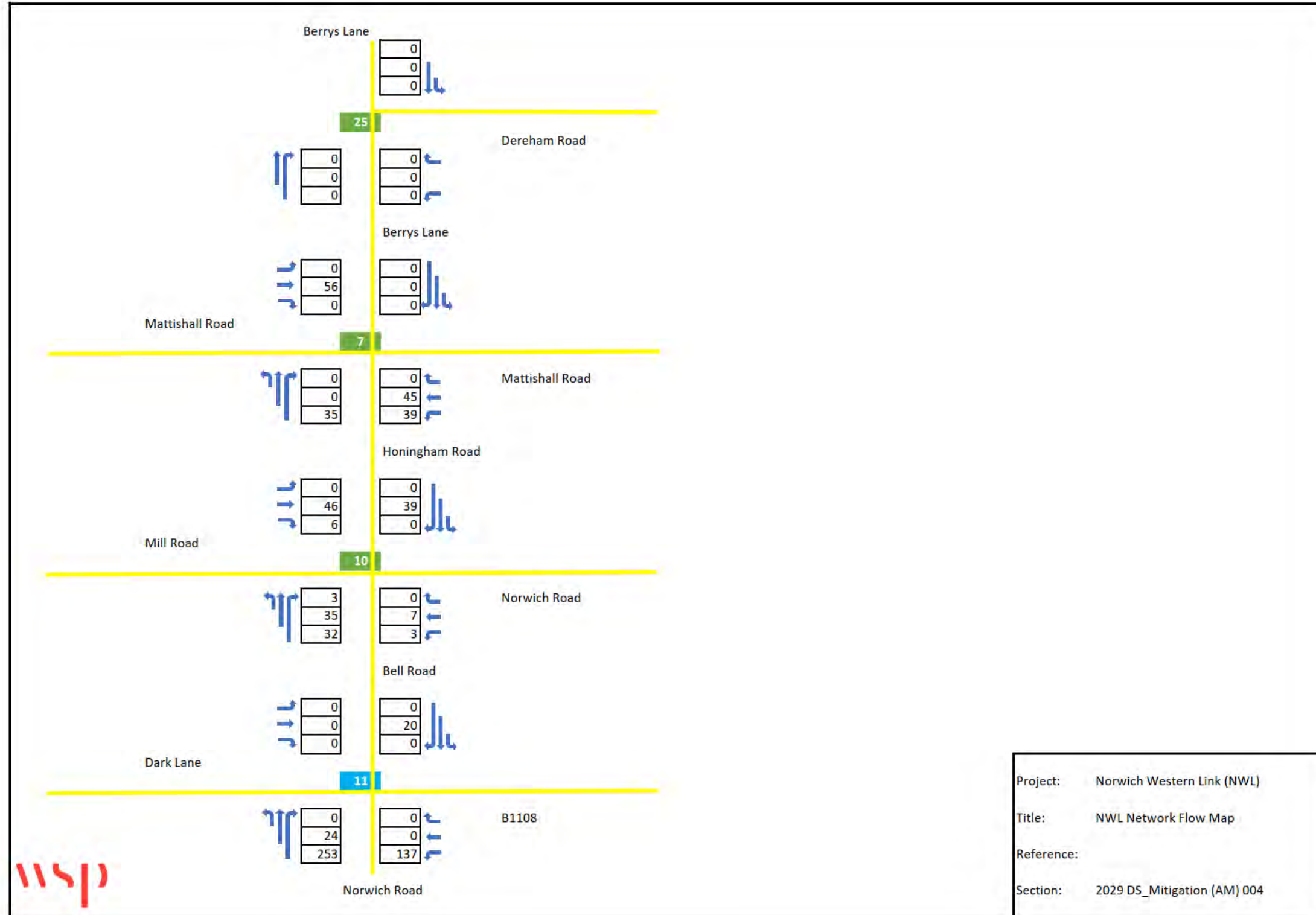






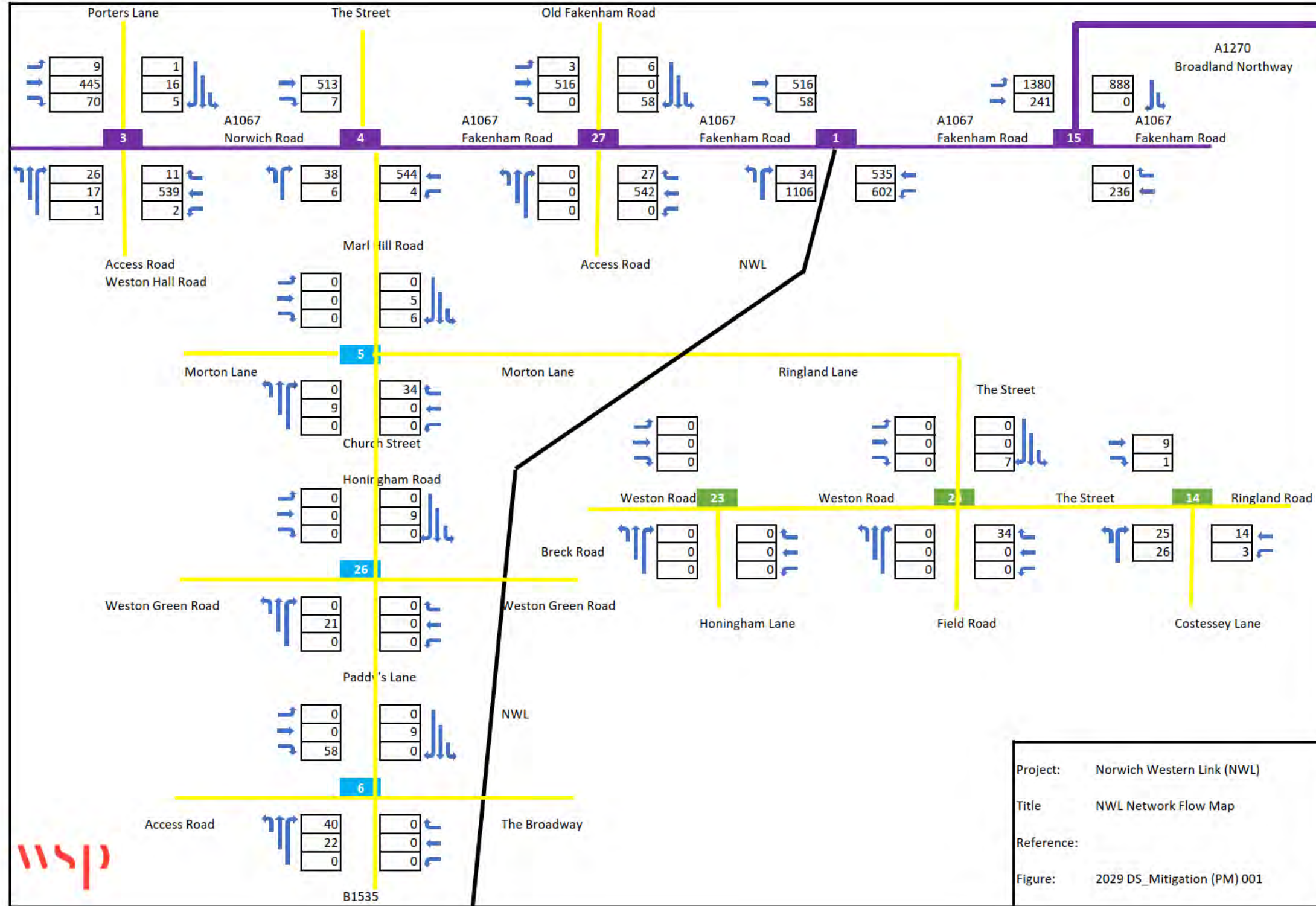
Project: Norwich Western Link (NWL)
 Title: NWL Network Flow Map
 Reference:
 Section: 2029 DS_Mitigation (AM) 003

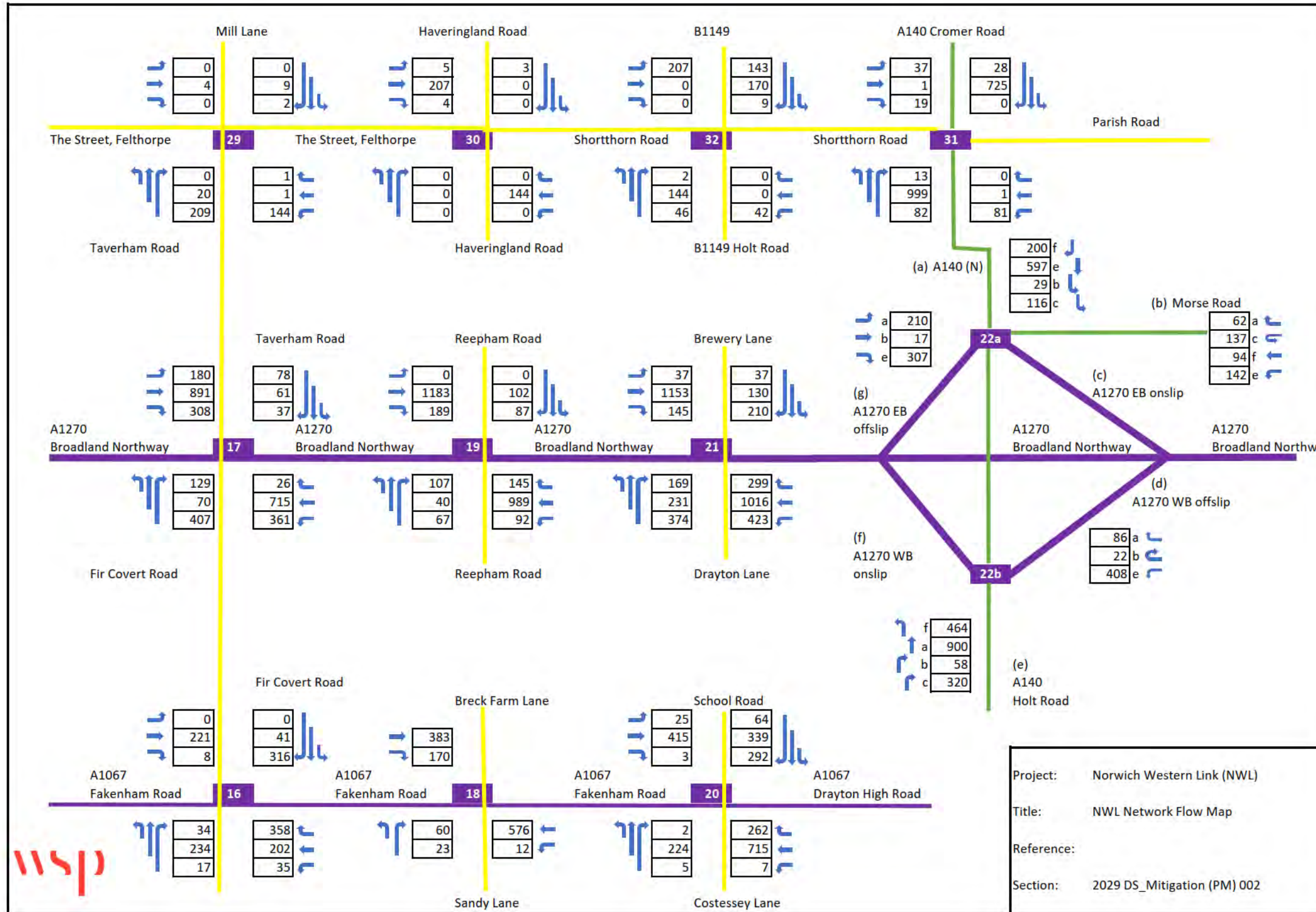


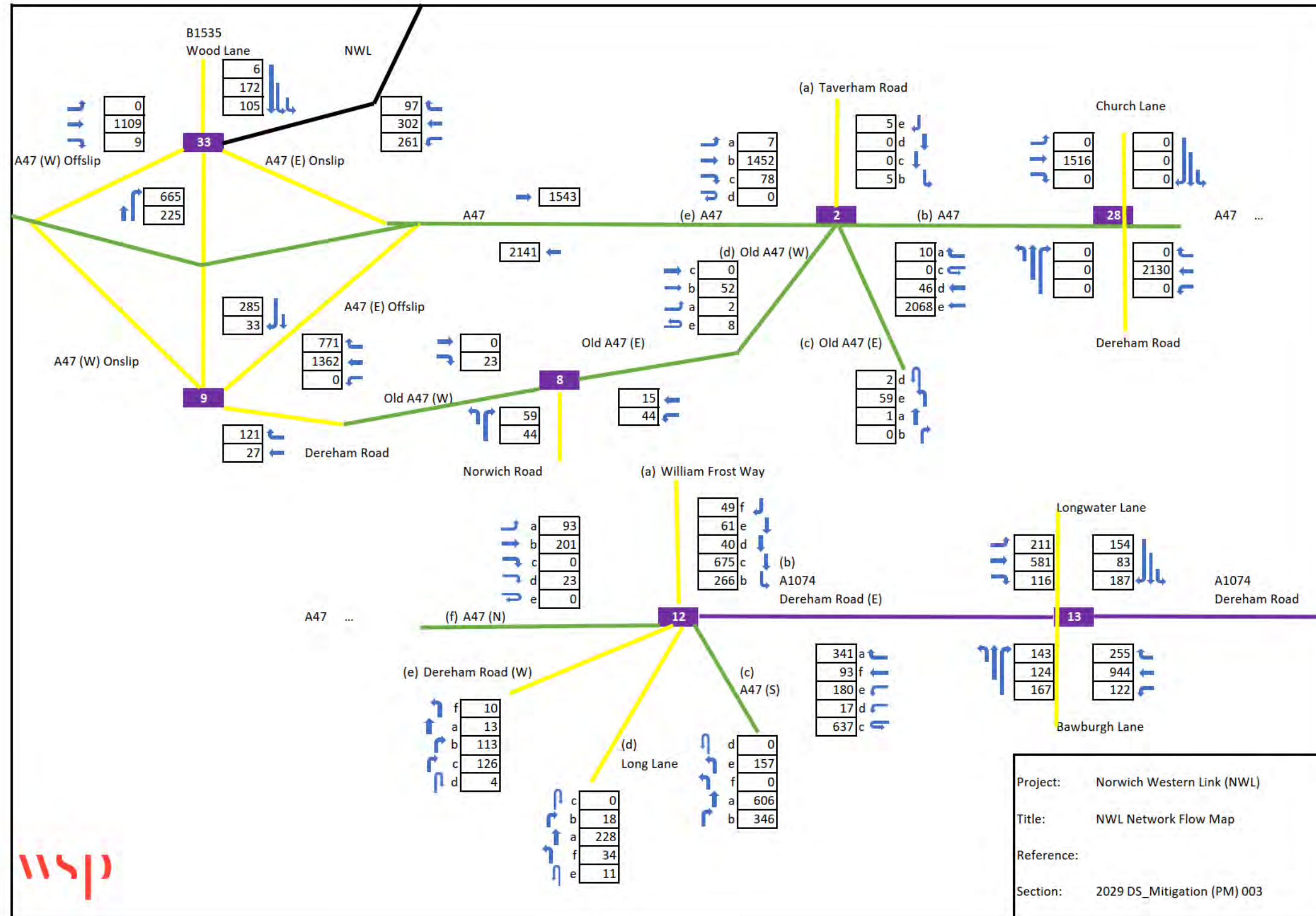


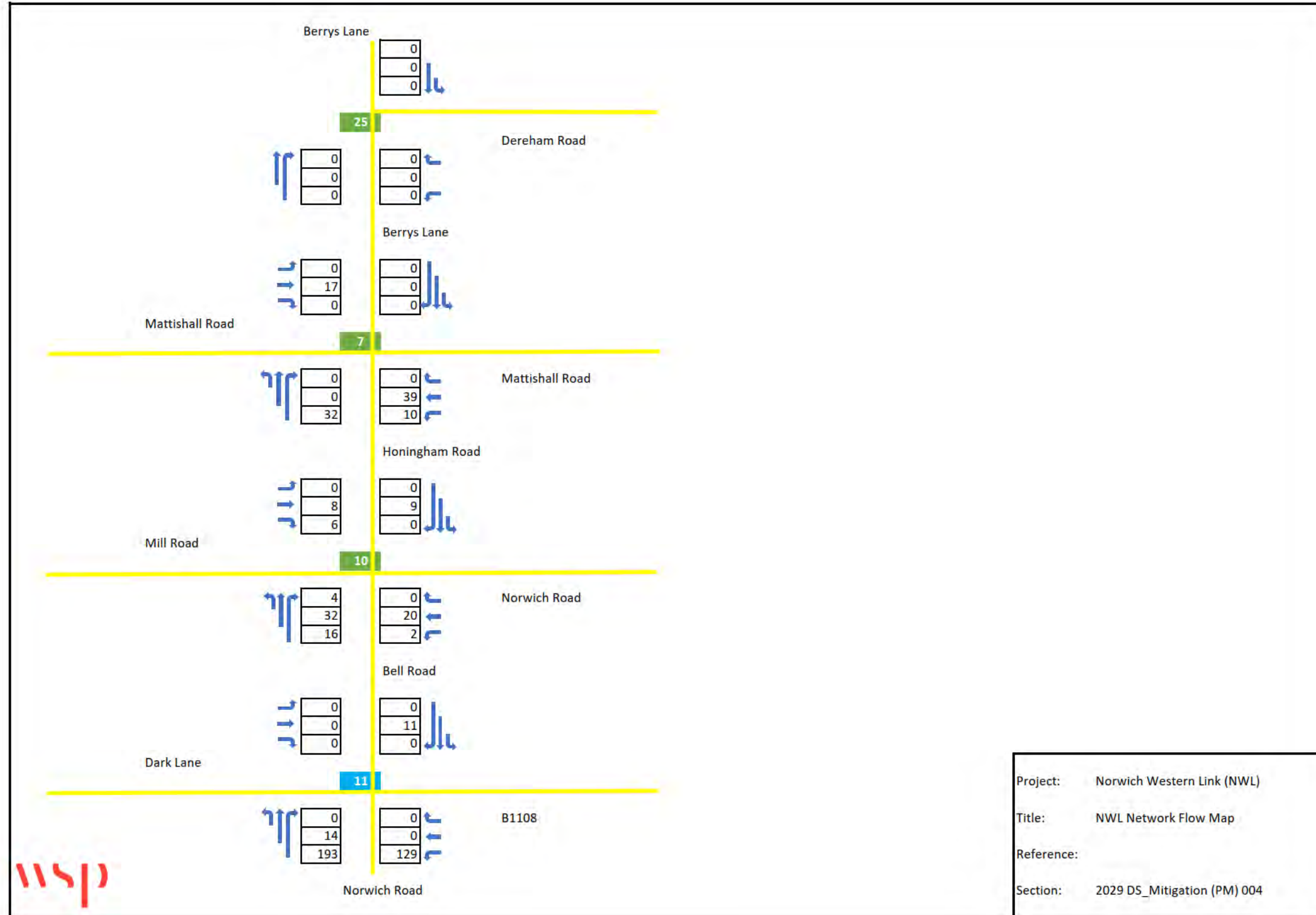
Project: Norwich Western Link (NWL)
 Title: NWL Network Flow Map
 Reference:
 Section: 2029 DS_Mitigation (AM) 004

Figure 1-6 2029 Do Something + Mitigation PM Peak





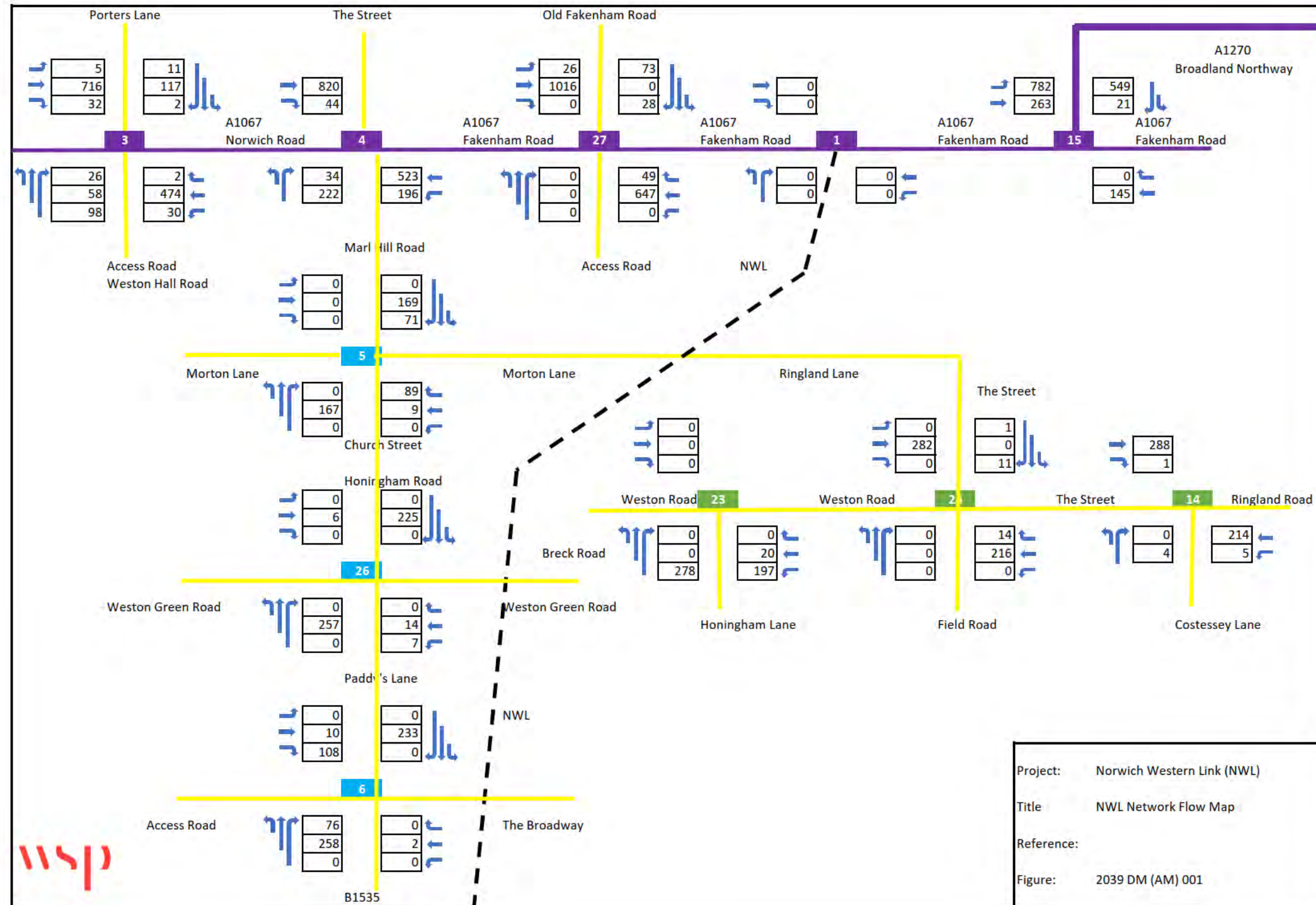


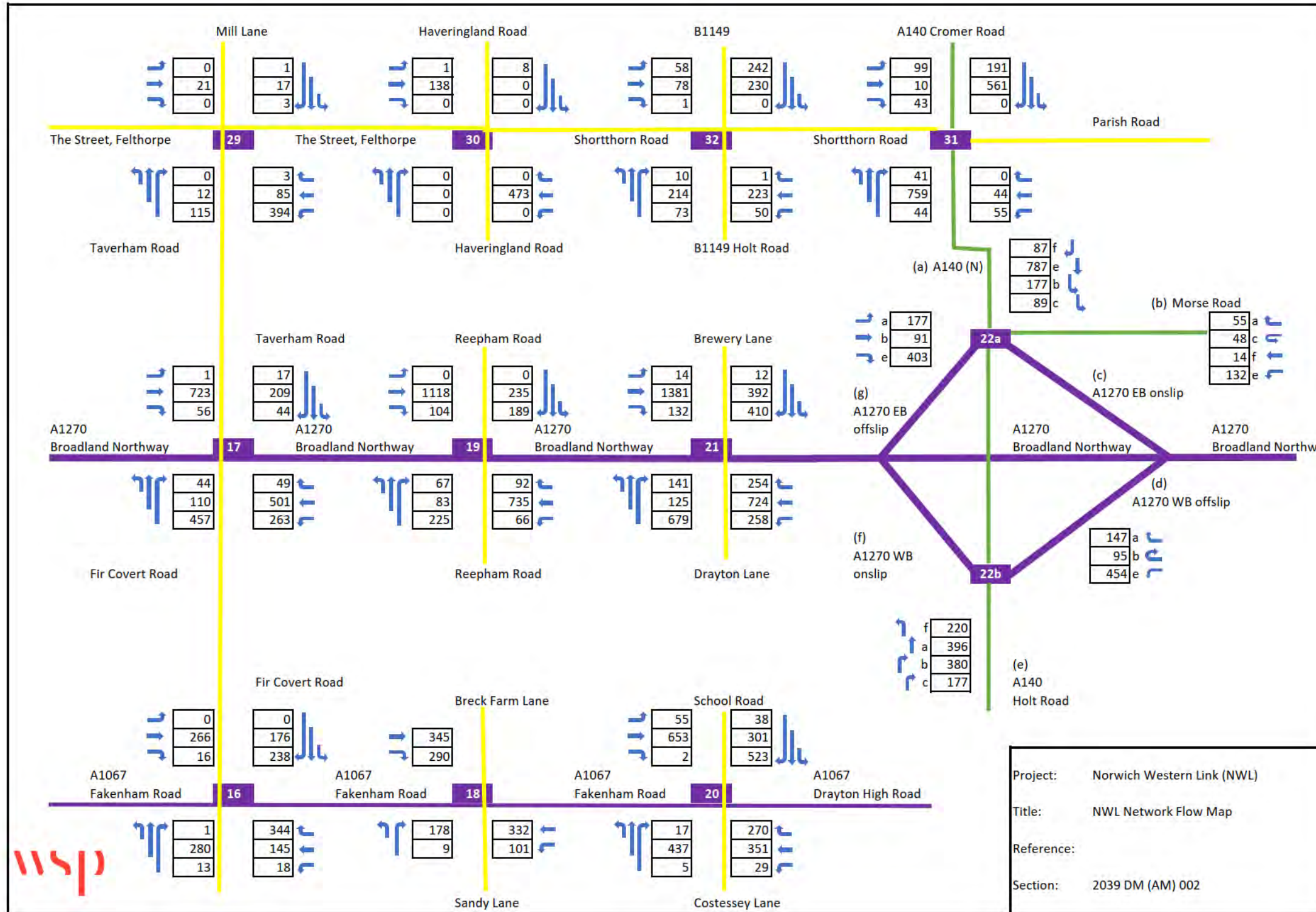


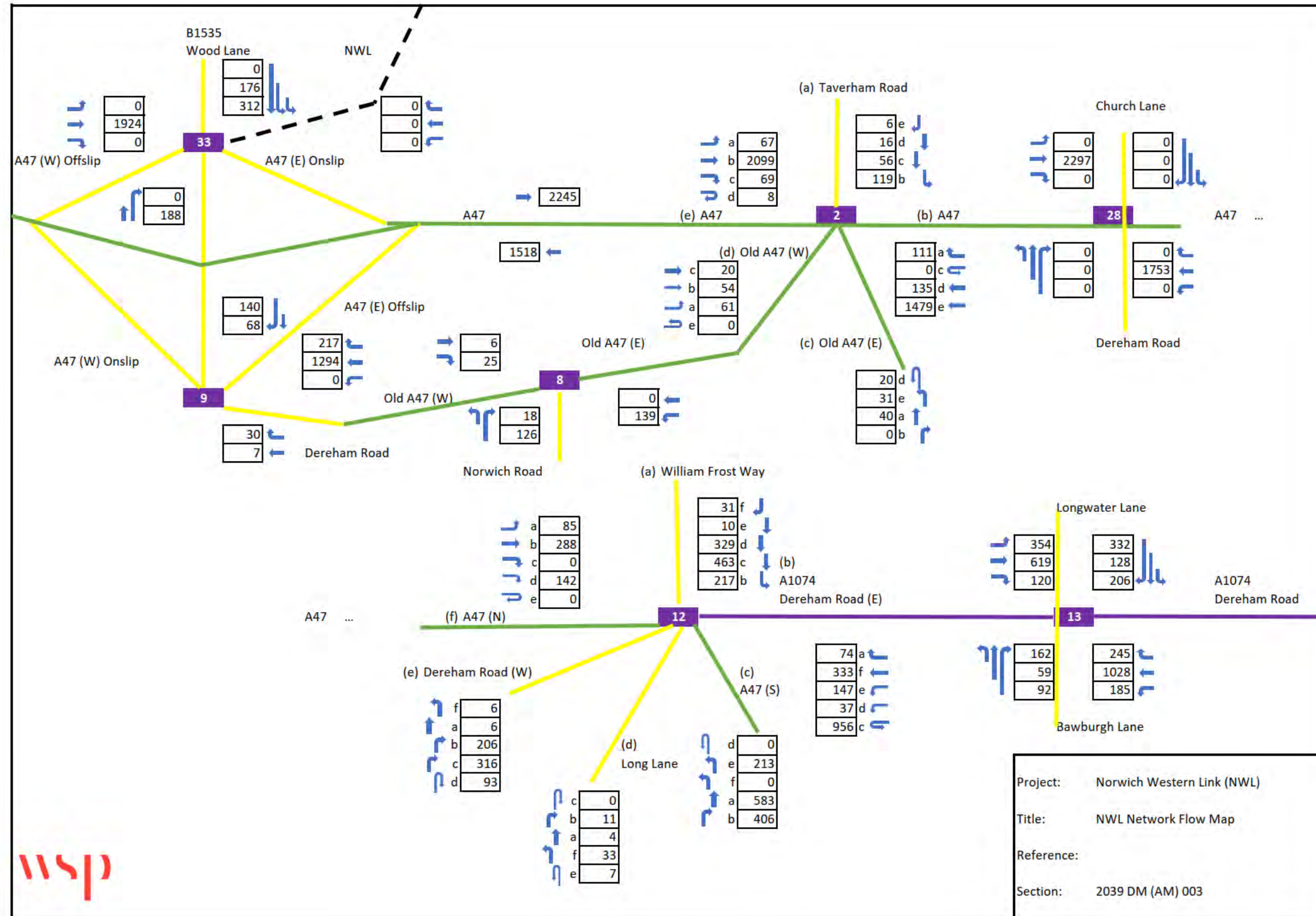
Project: Norwich Western Link (NWL)
 Title: NWL Network Flow Map
 Reference:
 Section: 2029 DS_Mitigation (PM) 004

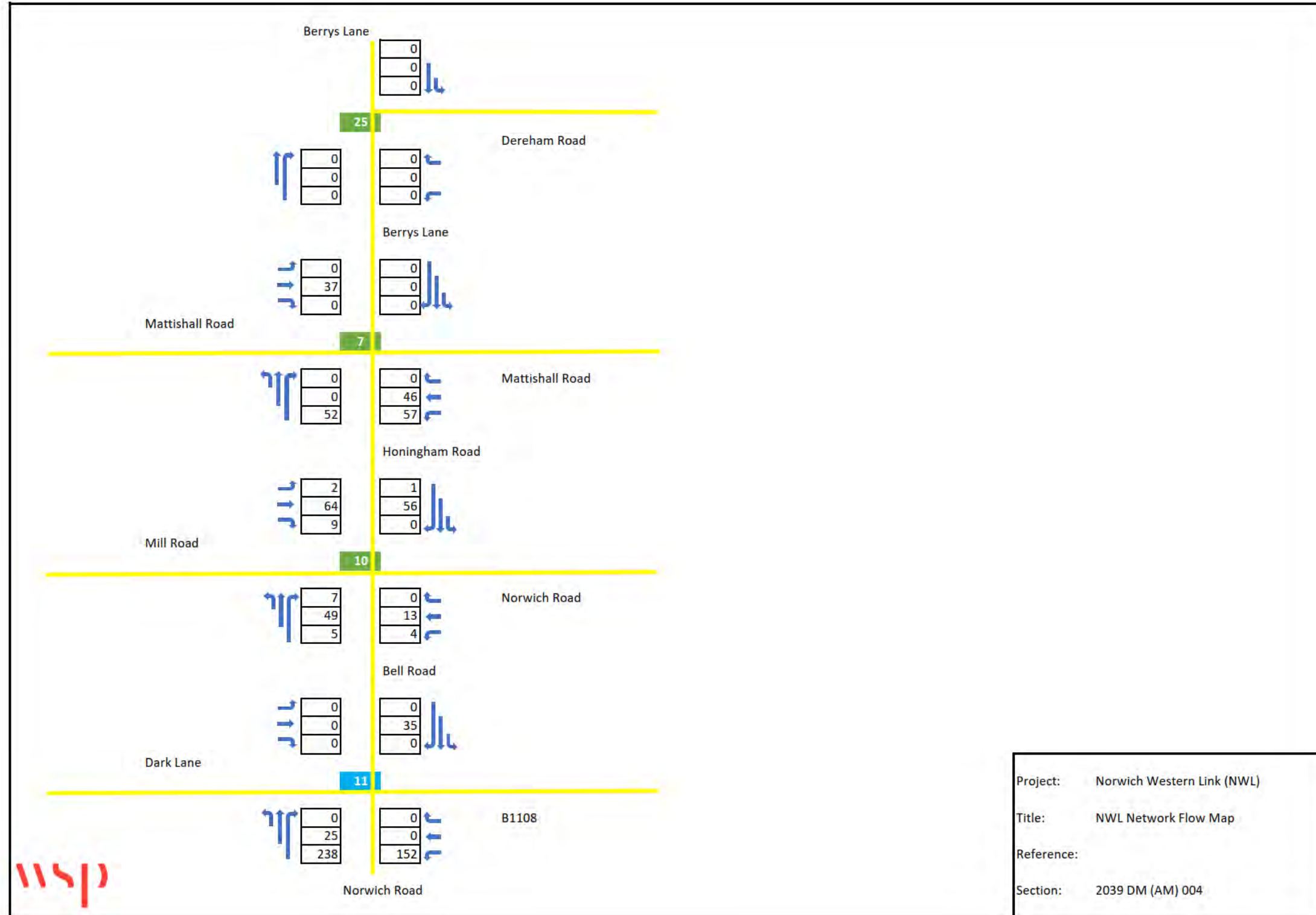


Figure 1-7 2039 Do Minimum AM Peak



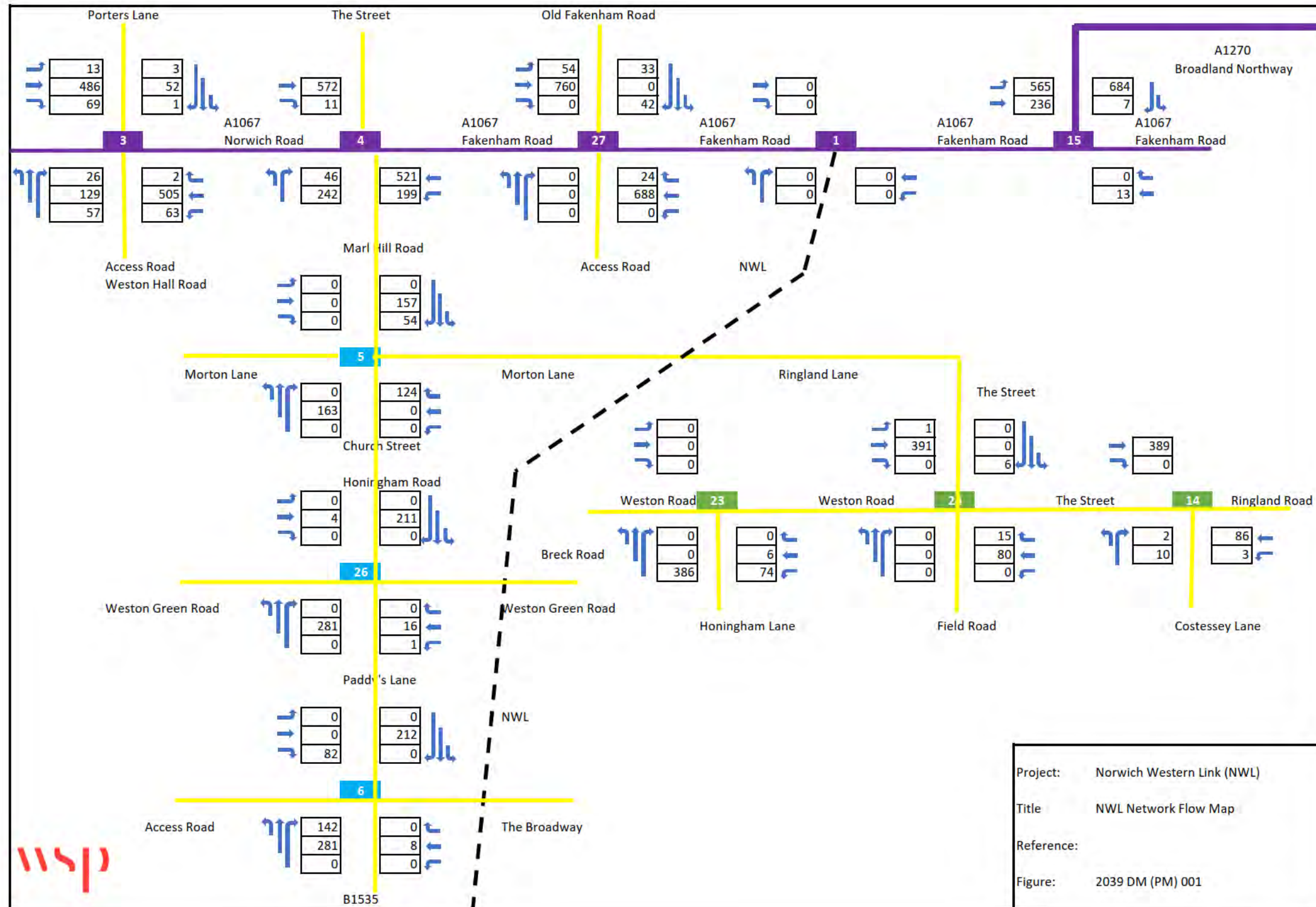


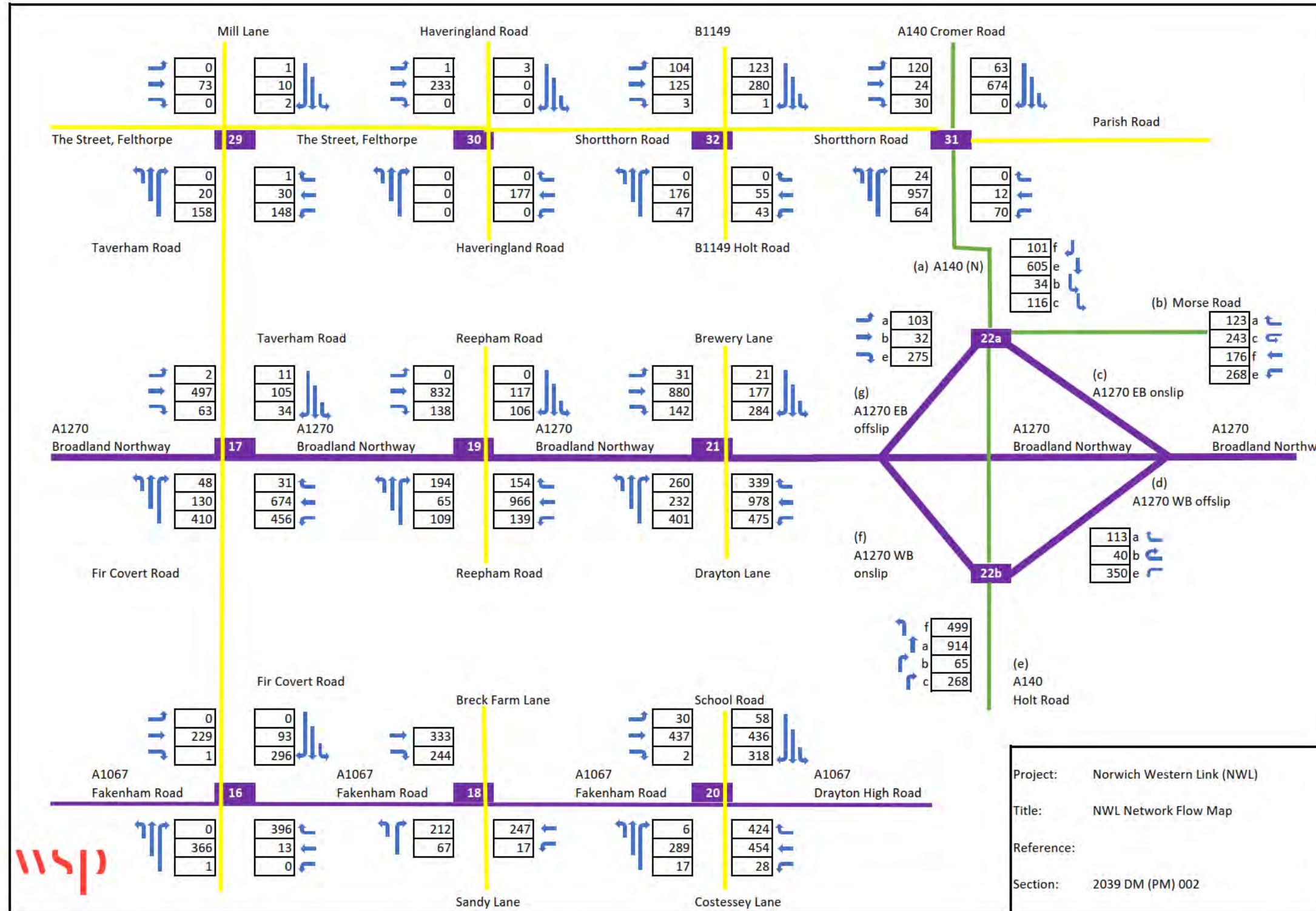


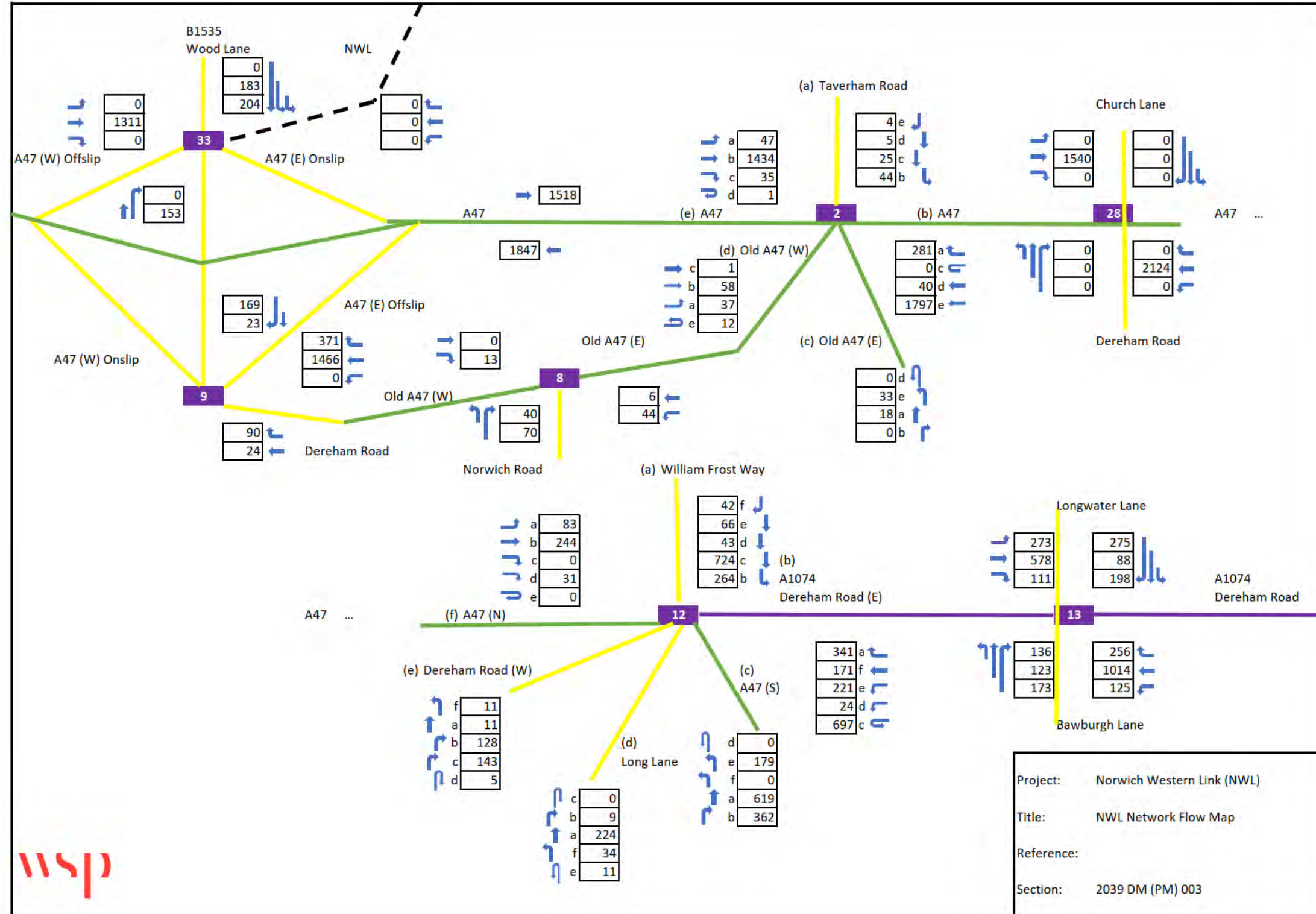


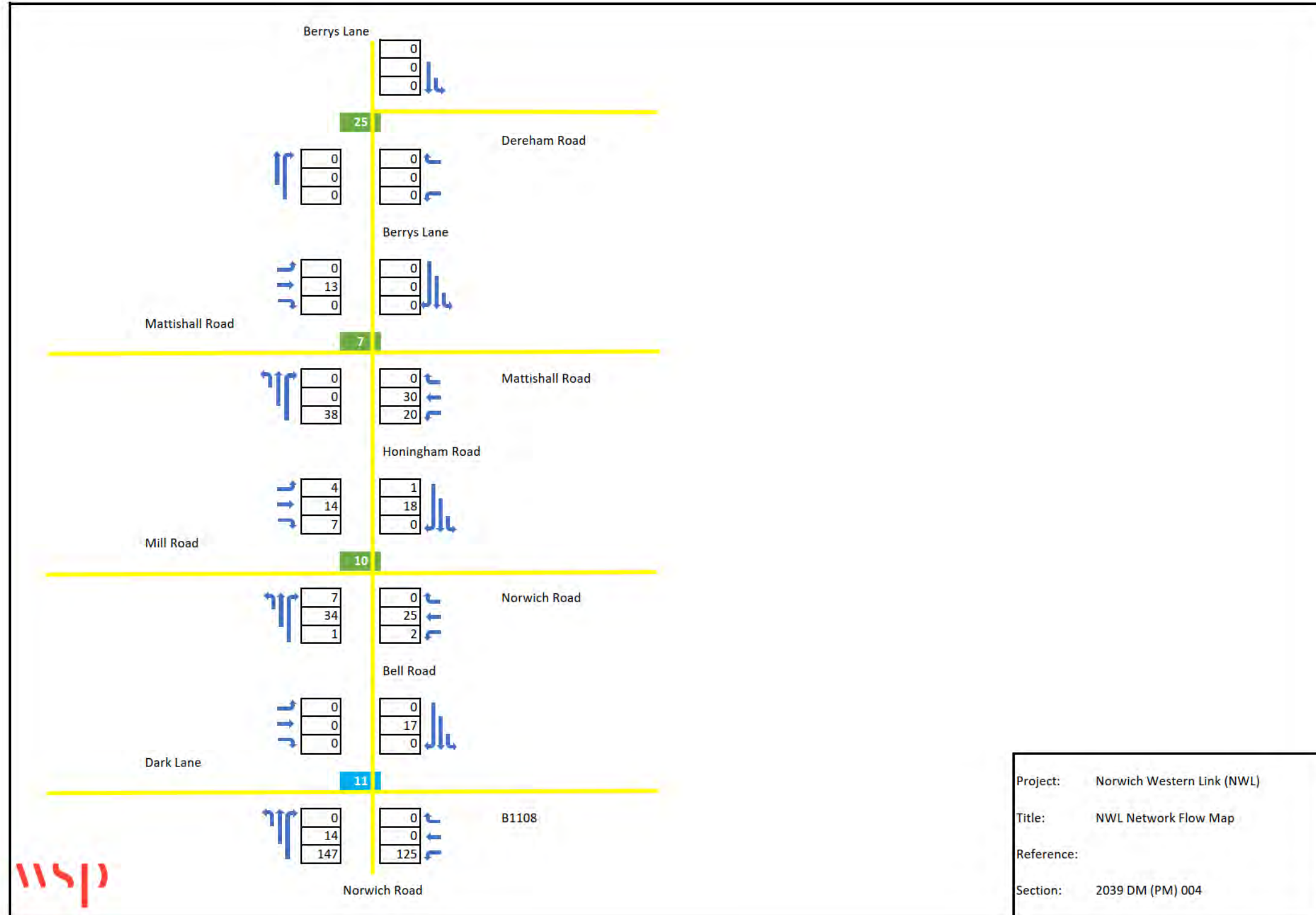
Project: Norwich Western Link (NWL)
 Title: NWL Network Flow Map
 Reference:
 Section: 2039 DM (AM) 004

Figure 1-8 2039 Do Minimum PM Peak





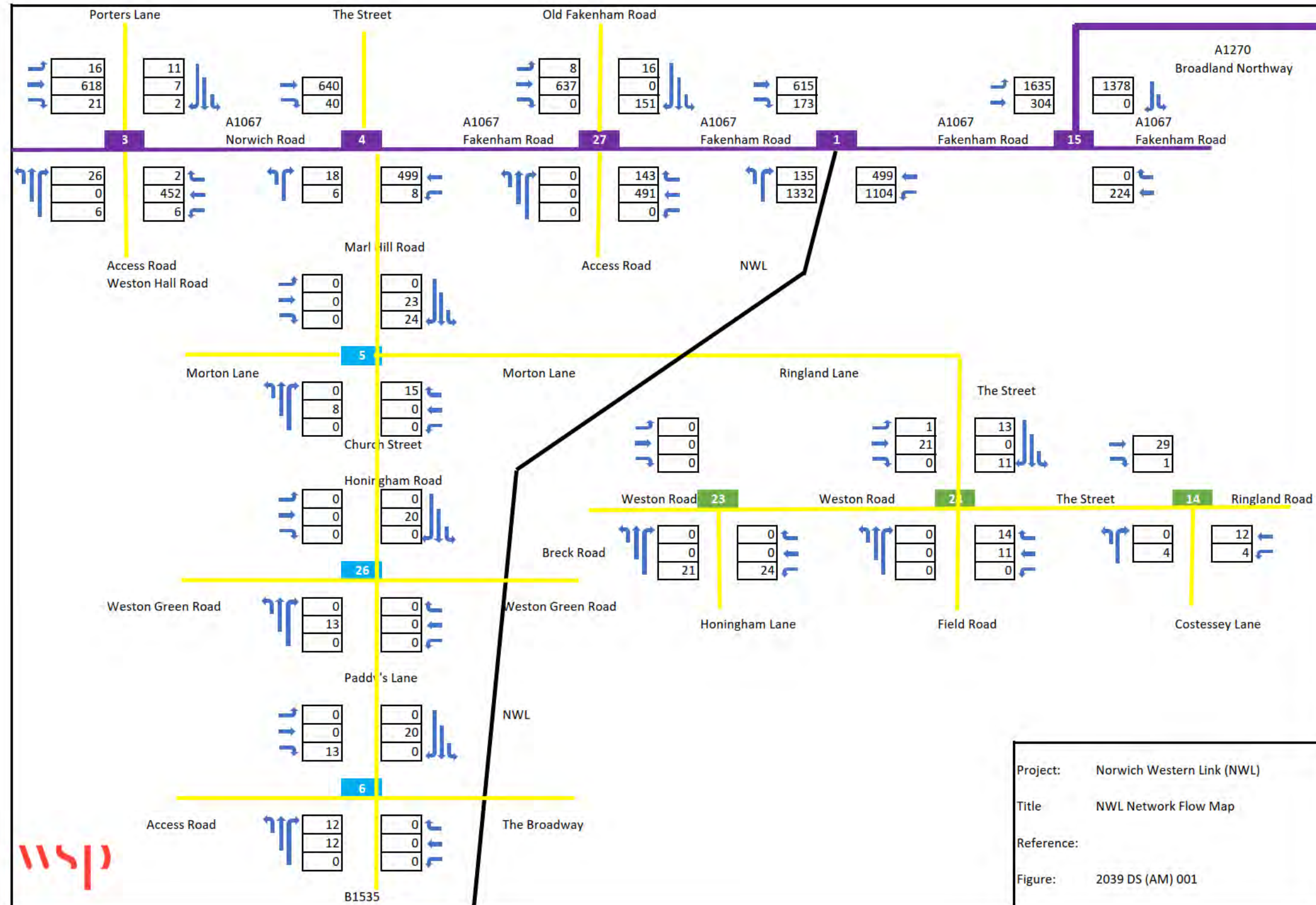


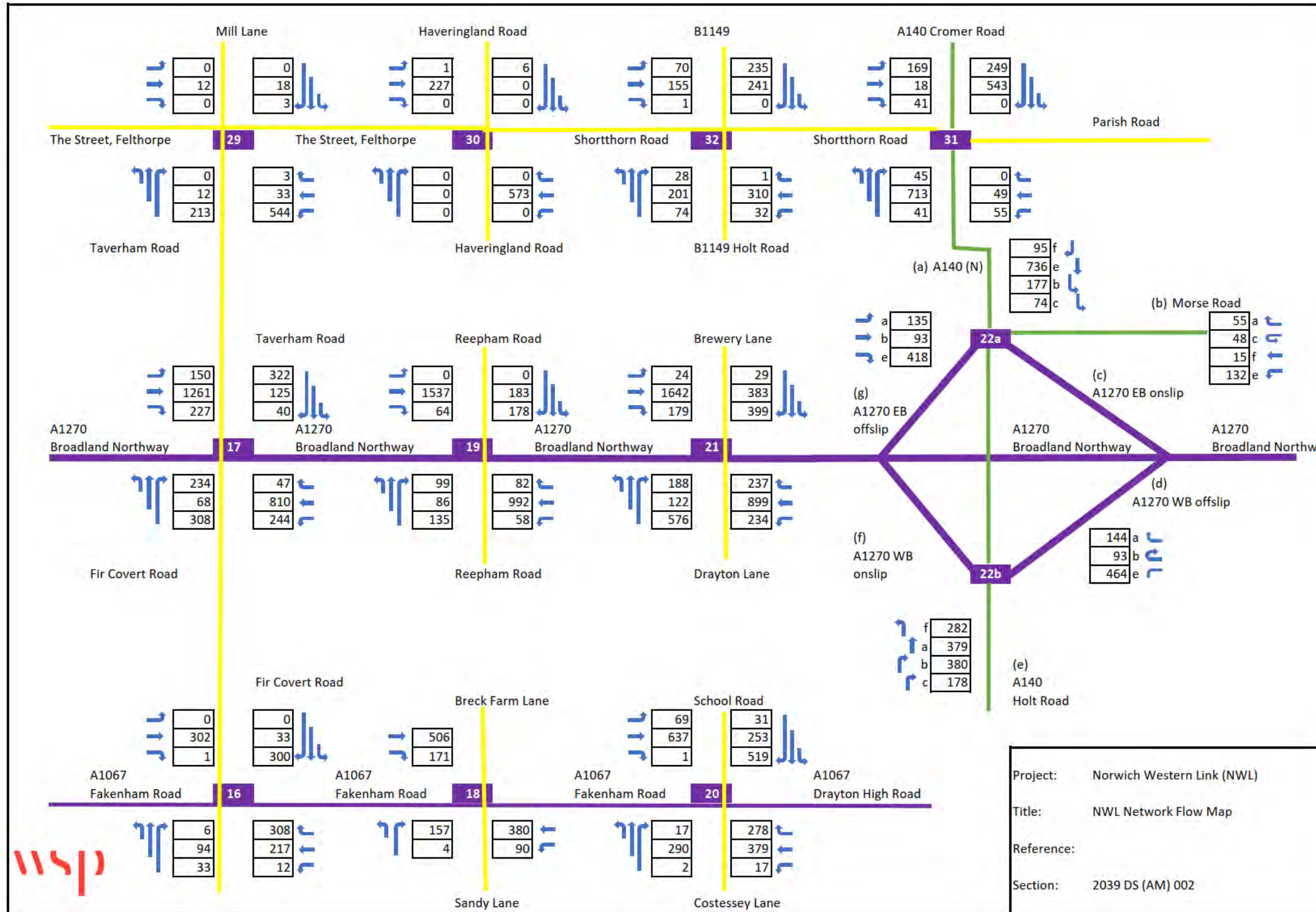


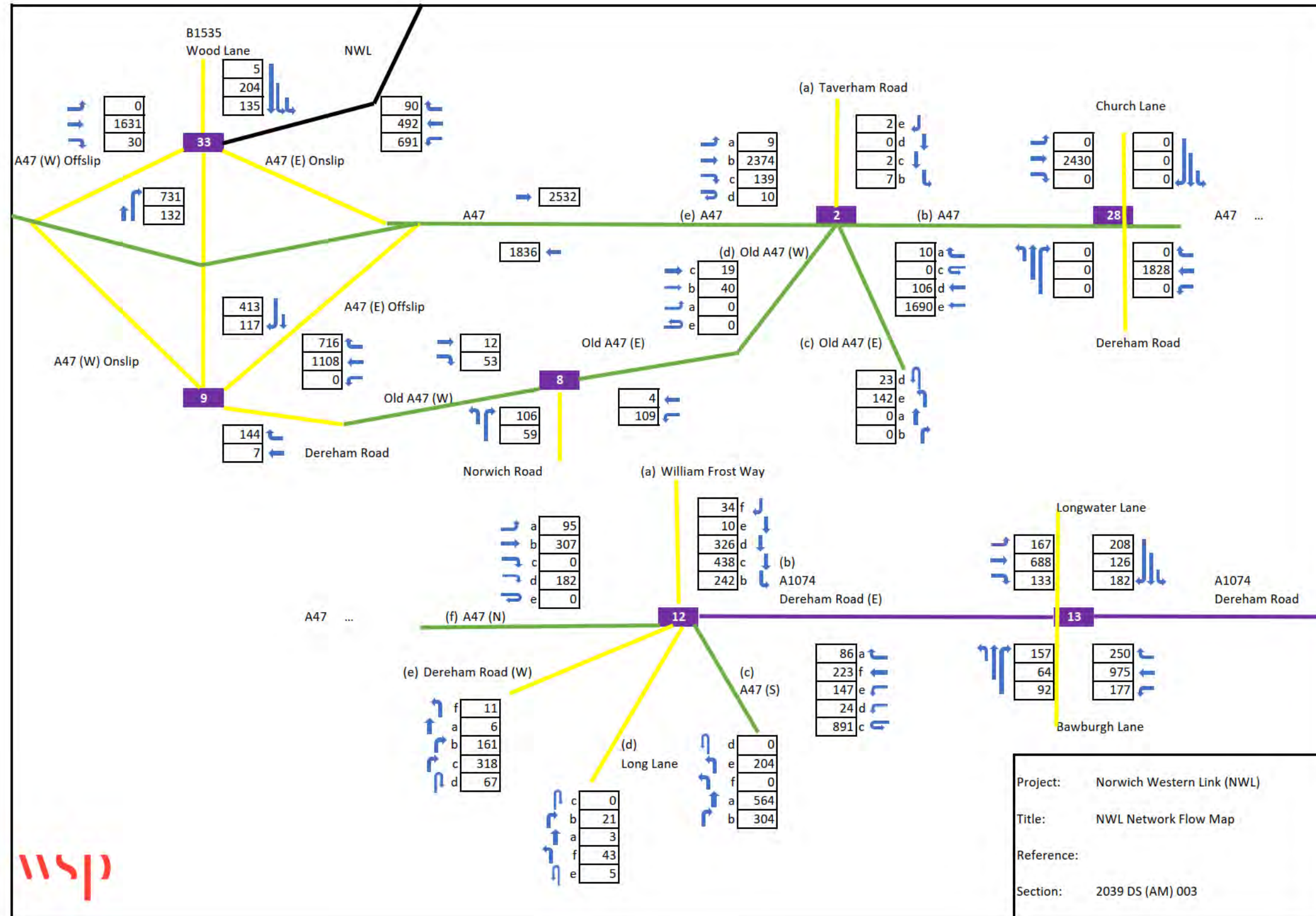
Project: Norwich Western Link (NWL)
 Title: NWL Network Flow Map
 Reference:
 Section: 2039 DM (PM) 004



Figure 1-9 2039 Do Something AM Peak







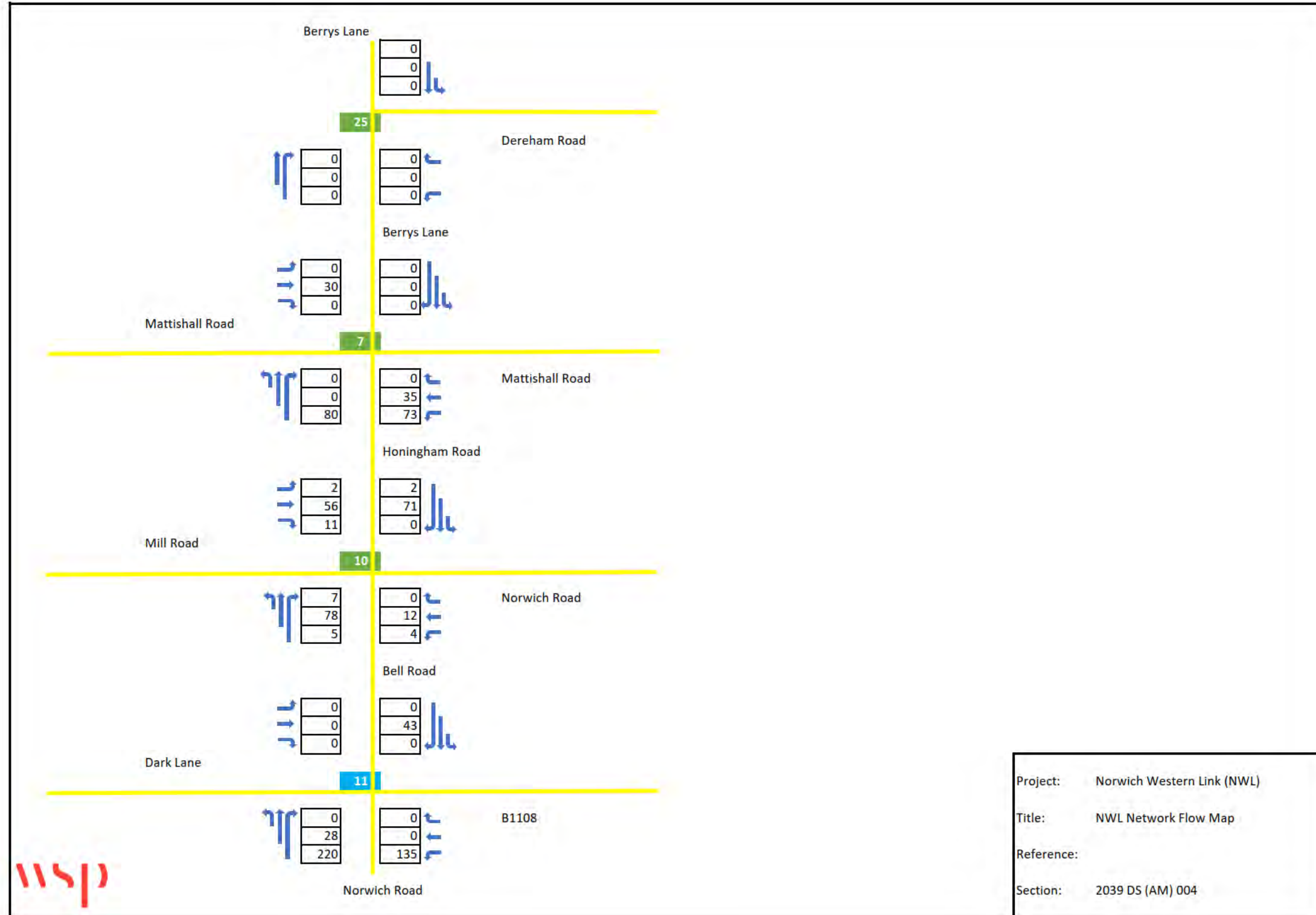
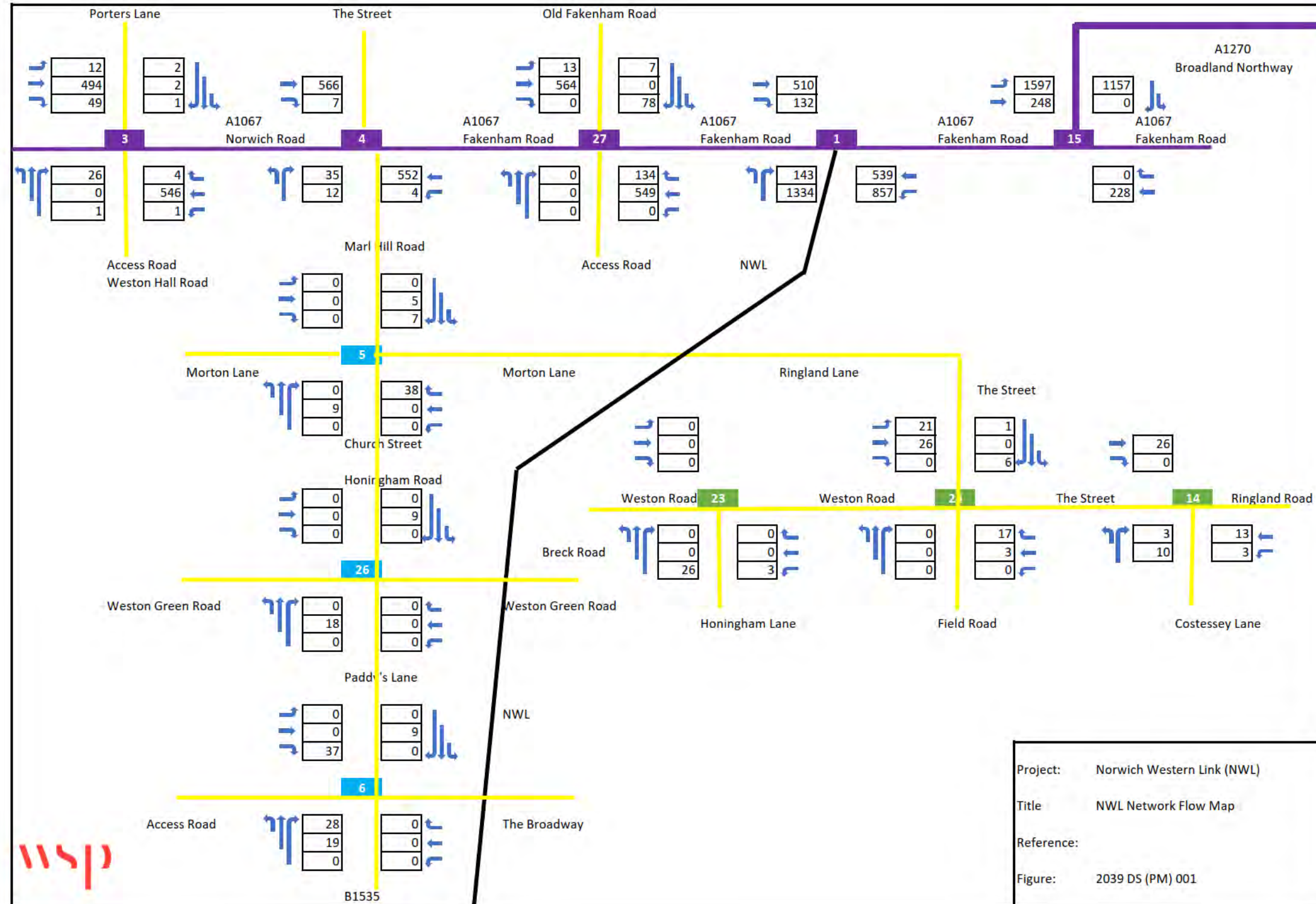
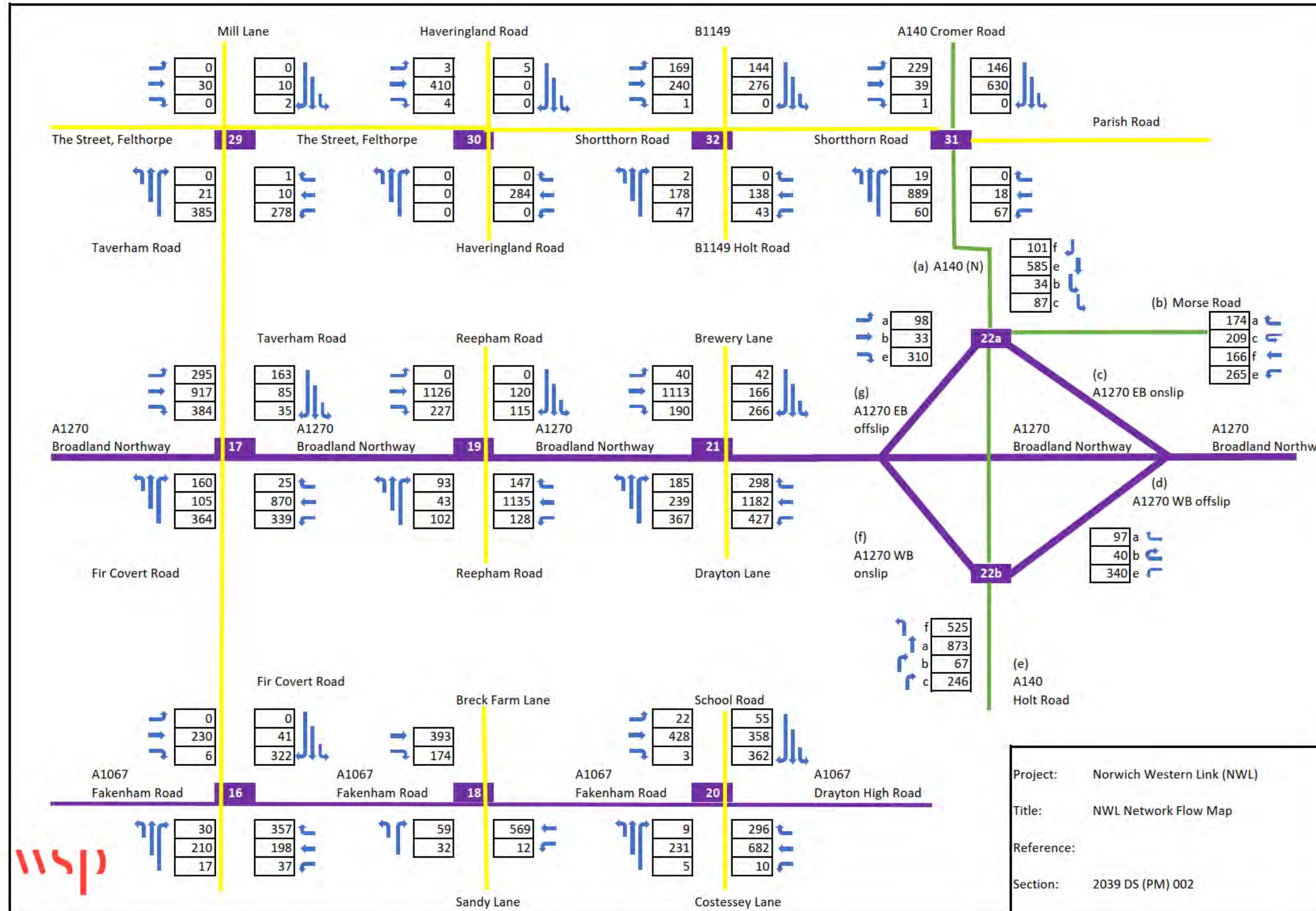
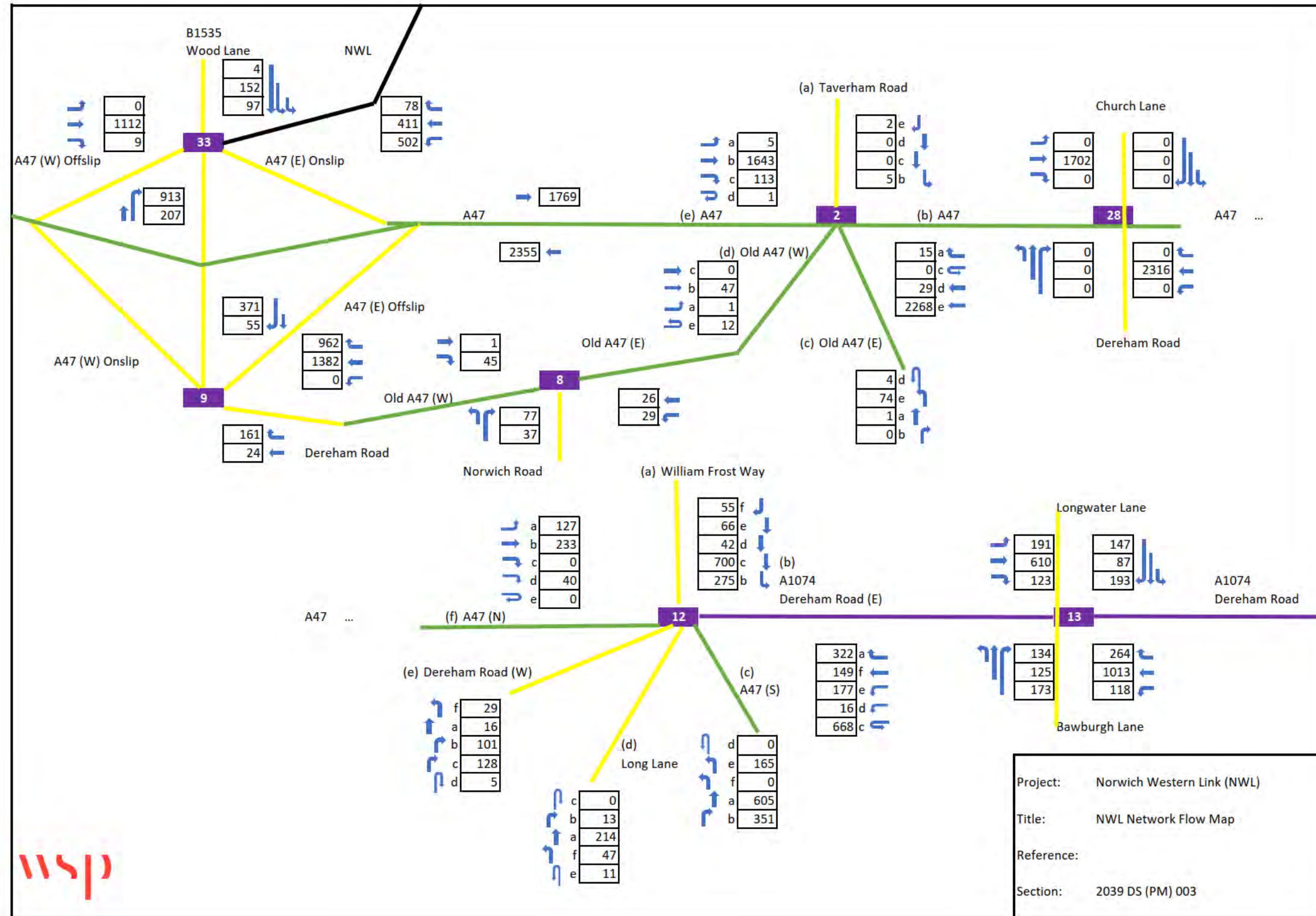
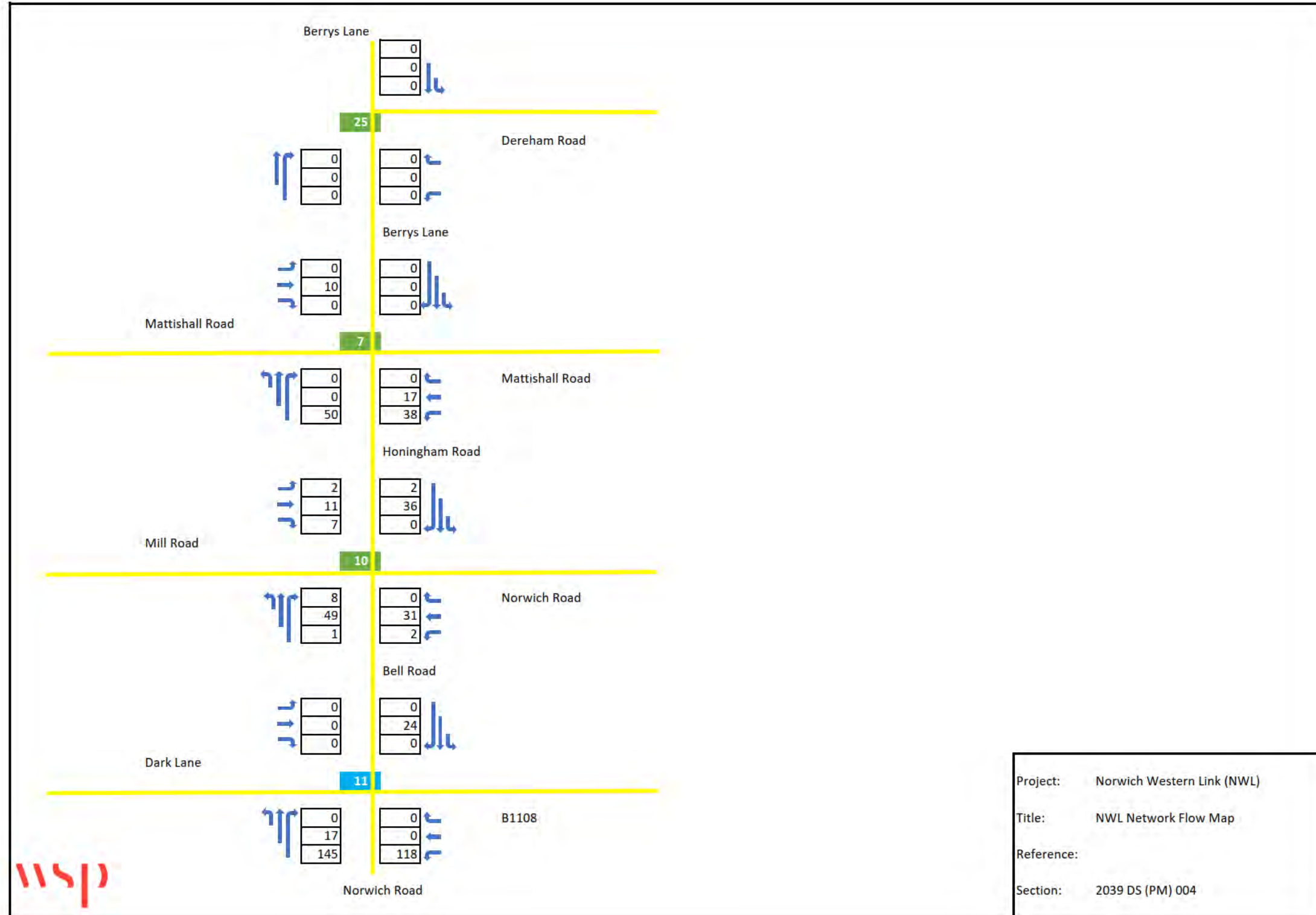


Figure 1-10 2039 Do Something PM Peak



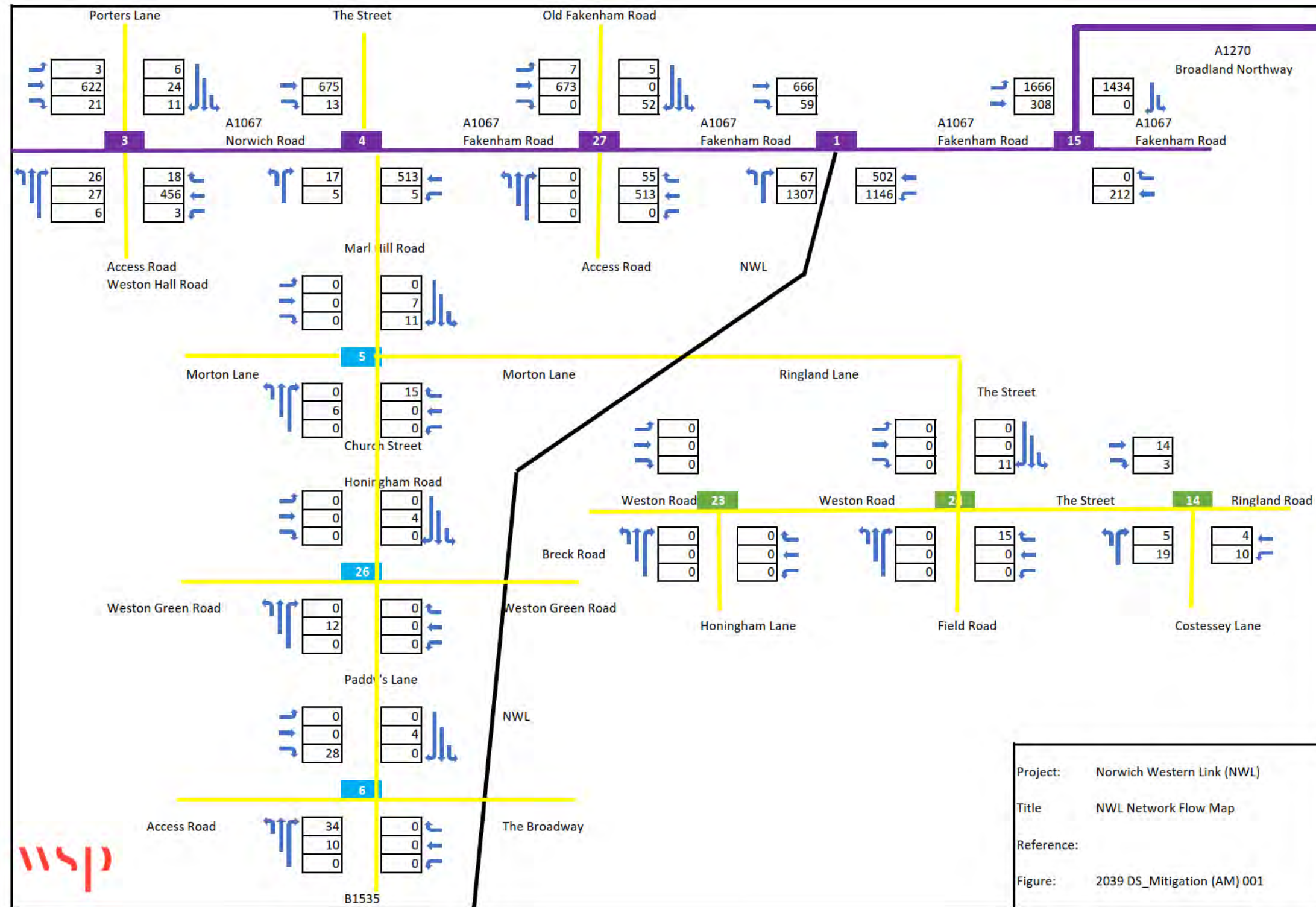


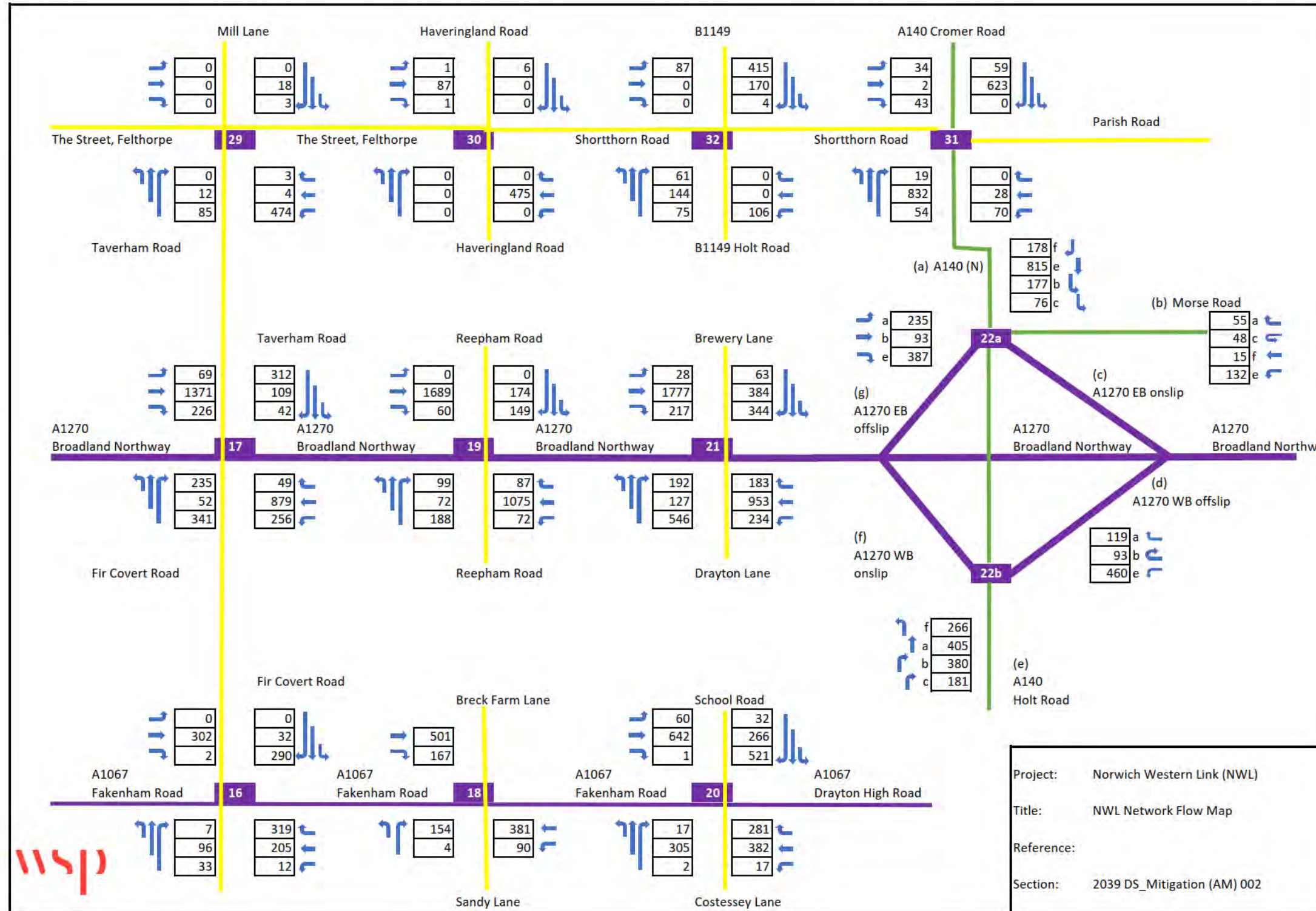




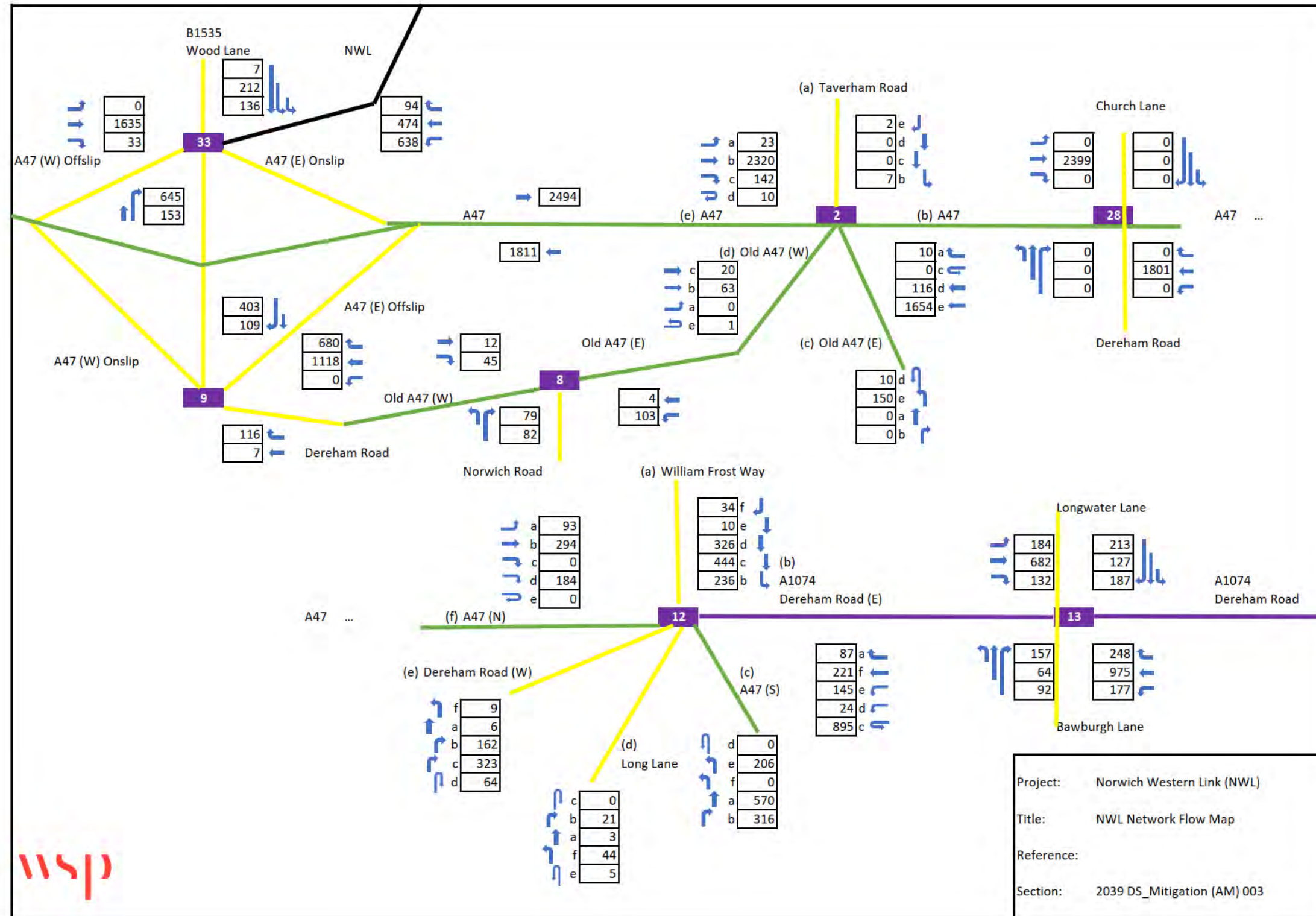
Project: Norwich Western Link (NWL)
 Title: NWL Network Flow Map
 Reference:
 Section: 2039 DS (PM) 004

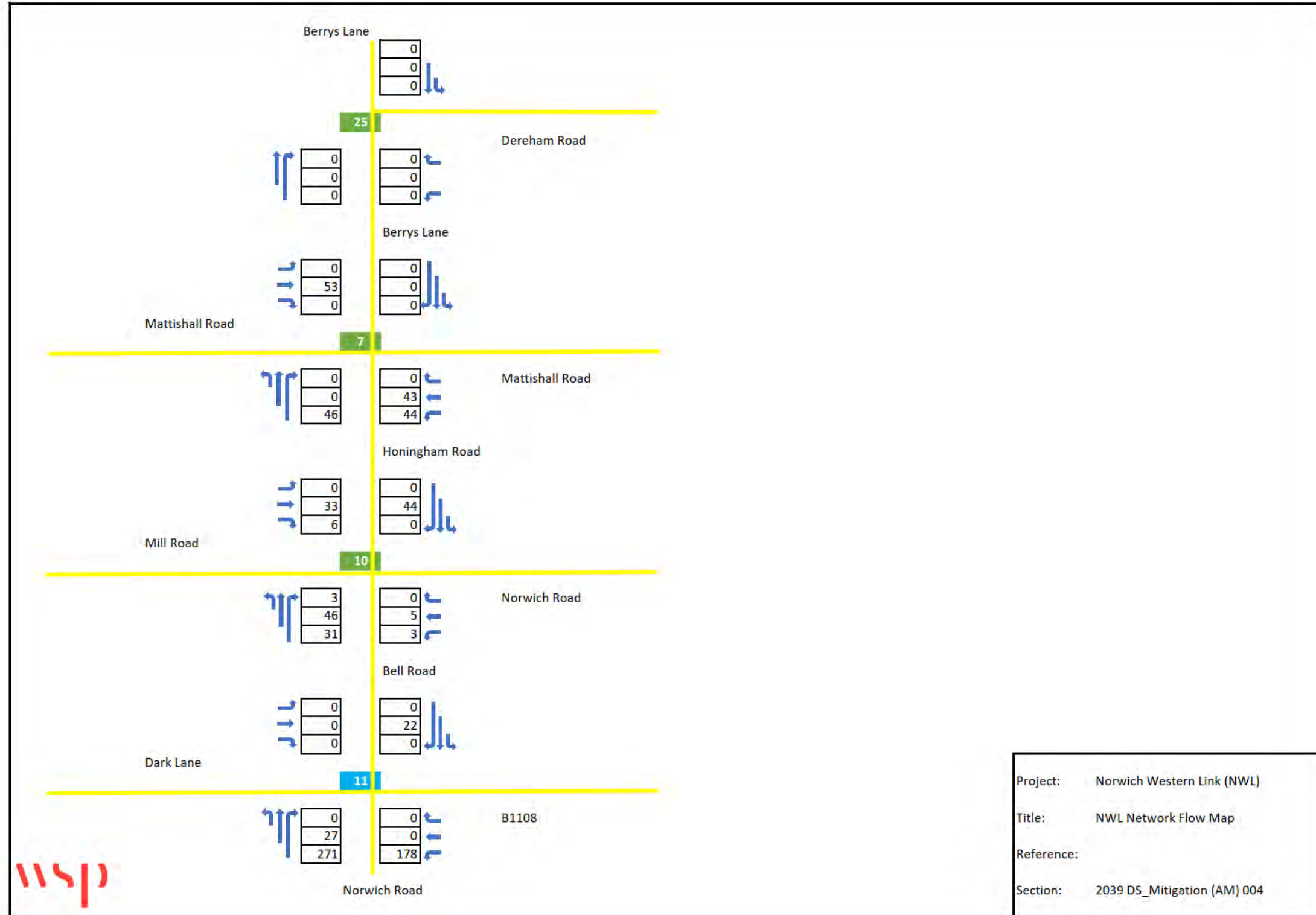
Figure 1-11 2039 Do Something + Mitigation AM Peak





Project: Norwich Western Link (NWL)
 Title: NWL Network Flow Map
 Reference:
 Section: 2039_DS_Mitigation (AM) 002





Project: Norwich Western Link (NWL)
 Title: NWL Network Flow Map
 Reference:
 Section: 2039 DS_Mitigation (AM) 004

Figure 1-12 2039 Do Something + Mitigation PM Peak

